

⚠ DANGER indicates a hazard which, if not avoided, will result in serious injury or death.

⚠ WARNING indicates a hazard which, if not avoided, could result in serious injury or death.

⚠ CAUTION indicates a hazard which, if not avoided, could result in minor or moderate personal injury.

NOTICE indicates information considered important, but not hazard-related (e.g. messages relating to property damage).

GENERAL SAFETY INSTRUCTIONS

⚠ WARNING

- Read and follow all instructions carefully.
- Disconnect and lock out power before installation and maintenance. Working on or near energized equipment can result in severe injury.
- Do not operate equipment without guards in place. Exposed equipment can result in severe injury or death.
- Read and understand the information in this section and in this manual completely before installing, operating or maintaining this equipment. Failure to follow this instruction could result in severe injury or death.

- Do not open or remove protective guarding if energy is supplied to any part of the Modsort Heavy Duty Module. Follow the lockout/tagout procedure according to safety procedures at the facility where the Modsort Heavy Duty Module is installed. Failure to follow this instruction could result in severe injury or death.

⚠ CAUTION

- Perform periodic inspections. Equipment may fail prematurely and could become unsafe if not properly inspected and maintained. Failure to follow this instruction could result in mild or moderate personal injury.

1.0 INTRODUCTION

The Marathon HGA series motors are designed and manufactured to be robust and reliable with minimal maintenance. The following items should be taken into consideration to ensure a trouble free installation and reliable running throughout the motor's life.

2.0 INSPECTION

The motors are delivered through safe and reliable transport in appropriate packing as to remain in as manufactured condition during transit. On receipt of the motor thoroughly inspect the unit for any transit damage, if need be in the presence of an insurance surveyor. For any equipment damage or shortfall, immediately contact The manufacturer for advise.

Check the following:

- Rating plate details and enclosure are as ordered.
- Shaft turns freely (in absence of shaft locking clamp).
- Condensation drain holes are in the correct position for the motor mounting application (they should be located at the lowest point of the motor when it is in its operating position).
- If the winding is Insulation Resistance (IR) tested to earth, ensure that the thermal protectors are not inadvertently damaged. (The thermistor leads should be shorted together whilst IR testing takes place.)

3.0 STORAGE

When the motor is not for immediate use store as follows:

- Clean and dry location.
- Free from vibration (vibration can damage bearings).
- Shaft locking clamps, where supplied, are fitted securely.
- Remove shaft locking clamps and turn rotor by one full rotation at least once a fortnight and replace shaft locking clamps.
- Anti-condensation heaters, where fitted, should be energised if the environment is likely to be damp.

4.0 INSTALLATION

The following items should be considered on installation to ensure reliable operation of the motor:

4.1 SURROUNDINGS

- Ensure that the motor is properly protected against ingress of oil, water or dust especially if construction work is in progress around the motor.
- Ensure air intake is not obstructed. Refer to dimension BL in the catalogue.
- **CAUTION!** When installing hazardous location motors, make sure that the zone and gas group or dust and temperature classification on motor nameplate are complied with.

4.2 MOUNTING

- Bed plates or slide rails should be firmly fixed to a solid, level foundation to ensure the motor remains rigid and vibration free.
- Shims or packers (if required) must be of adequate size and placed adjacent to and between base fixing screws.
- Protective transport coatings on shafts and/or flanges must be removed prior to connection to the driven load.
- A light coating of grease to shafts and/or flanges will inhibit corrosion during service and assist removal of pulleys or couplings.

4.3 PULLEYS AND COUPLINGS

- Pulleys or couplings should be independently balanced with a half key as the motor rotor is balanced with a half key during manufacture.
- In fitting pulleys or couplings to the motor shaft care must be taken to ensure the roller/ball bearings are not damaged. Both shaft and coupling bore should be cleaned and lubricated. If the fit is still too tight, the pulley or coupling should be pre-heated in air or oil to enable easy assembly.
- Shock methods must not be used in fitting or removing pulleys or couplings. Proper wheel or pulley removers should be used to prevent shaft and bearing damage. Tapped holes are provided in shaft extensions to assist in the fitment of couplings and/or pulleys.

4.4 PULLEY AND BELTS

- If the motor is to be coupled to the load using pulleys and belts it is important to ensure that the belt tension does not exceed the safe working radial load of the motor. Excessive radial load will lead to reduced bearing life with the potential of breaking the motor shaft. Because of this care must be taken to ensure the correct selection of pulley size and type (toothed, vee or flat) and this is best done in consultation with the transmission supplier.
- **NOTICE:** The belt manufacturer’s recommendations for installation, alignment and tensioning must be strictly adhered to when fitting belt drives.

4.5 ALIGNMENT

- Great care must be taken in aligning the complete machine, since misalignment can cause rapid deterioration of bearings and lead to other mechanical failures due to the stress produced.
- After final tightening of foundation bolts, machine alignment should be rechecked as bed plates could move and/or distort during machine mounting.
- No end thrust should be applied without express approval.
- When slide rails are used in conjunction with pulley drives, the adjusting screw ends should be positioned between the motor and load at drive shaft end and the other diagonally opposite. This helps speedy and accurate belt aligning, tensioning and replacement.

The correct alignment of the motor pulley with the load pulley is imperative. Both these pulley’s must have matched centre distances between grooves and alignment must be carried out using a suitable metal straight edge or other recommended tools to ensure parallel offset or angular displacement of the pulley’s with respect to each other is inside permissible limits as recommended by the transmission supplier.

Correct alignment will result in a uniform distribution of belt tension across the width of the pulley (and the motor shaft) and ensure design life of both the belts and bearings is achieved.

NOTE: The pulley should always be mounted firmly against the shaft shoulder and should be a firm fit onto the shaft. **Impact force must not be used.**

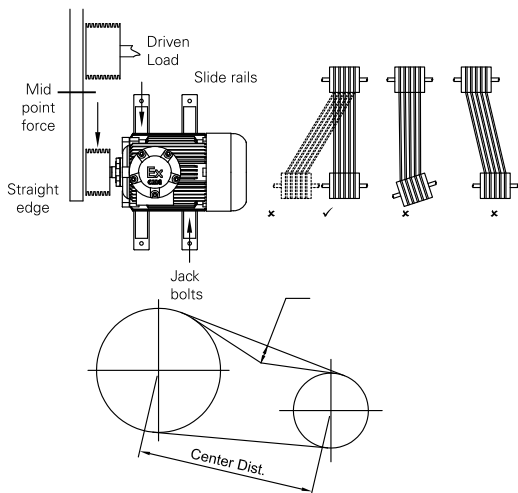

As a general rule the mid point of the applied force should be at the mid point of the shaft and it is good engineering practice to mount the motor pulley with hub and locking screw at the shaft end.

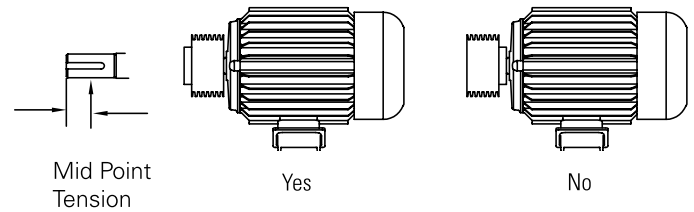

DIRECT COUPLED

Where direct coupling of the motor is required, proper alignment must be achieved to prevent bearing damage to both motor and load.

For parallel offset, use a straight edge or other recommended tools, as shown below.

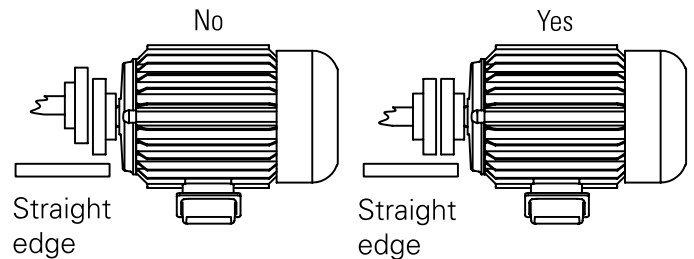

Excessive angular displacement must also be prevented. The recommended method to achieve correct angular alignment is shown below.

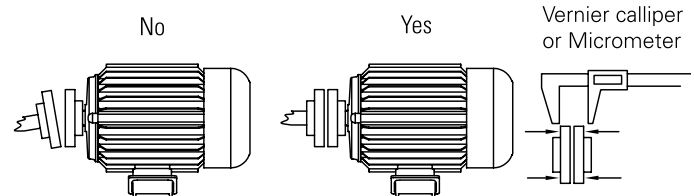

NOTE: The pulley should always be mounted firmly against the shaft shoulder and should be a firm fit onto the shaft. **Impact force must not be used.**

4.6 AXIAL LOADS

Where motors with standard bearings are required to be mounted in either vertical shaft up or vertical shaft down orientation, there are limits on the axial forces that must not be exceeded. This also applies to horizontal mounted motors with certain loads that produce axial thrust. Axial loads exceeding those listed in the catalogue will reduce bearing life and may lead to internal motor damage.

Where higher than recommended axial loads are necessary different bearing types will be required. Please contact the manufacturer for advise.

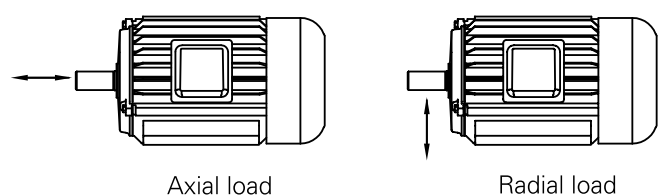

5.0 COOLING

There are various cooling formats for electric motors with IC411 (totally enclosed fan cooled) as the most common type that is used on our HGA motors. This type of cooling of motor is achieved by a fan mounted at the non drive end, inside a fan cowl, which has an air inlet grille at the rear. Air is drawn in through the grille and the fan distributes the airflow along the fins of the motor body. The fan is designed for either direction of rotation (unless otherwise indicated on the fan cowl).

With TEFC motors it is important that the cooling fins remain clear of debris to allow the airflow to be fully effective in maintaining motor winding temperature within the design limits.

It is equally important to ensure the installation provides good unrestricted access to normal ambient air at the fan entry point at all times and that the inlet grill is clear of contaminants. Refer to dimension BL below.

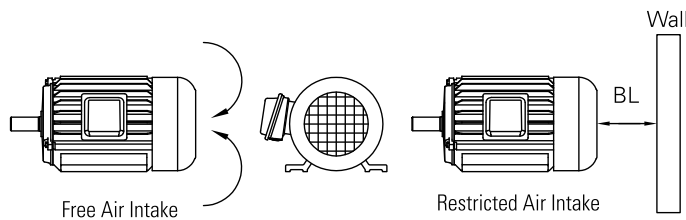

| Motor frame | Dimensions BL [mm] |
|-------------|----------------------|
| 80 - 100 | 15 |
| 112 - 132 | 30 |
| 160 - 180 | 40 |
| 200 - 280 | 50 |
| 315 | 65 |

6.0 HAZARDOUS LOCATION MOTORS

CAUTION! Standard motors in the range of frame sizes 80 to 315 with appropriate modifications are certified for use in hazardous areas as below. (Note: 315 frame certified for Ex nA & Ex t only under IEC Ex scheme.)

| Increased safety motors |
|-----------------------------------------------------------------------------------------------------|
| Exe, Zone 1, Group II Temperature class T3 |
| Marking code: Ⓜ II 2 G Ex e IIC T3 Gb IP55 (OPTION IP66) (T _{amb} -20°C to 40°C) |
| Non-sparking motors |
| Ex nA, Zone 2, Group II Temperature class T3 |
| Marking code: Ⓜ II 3 G Ex nA IIC T3 Gc IP55 (OPTION IP66) (T _{amb} -20°C to 50°C) |

Dust Excluding Ignition Proof

Ex t Zones 21 & 22
Temperature class T4

Marking code:
Ⓜ II 2 D Ex tb IIIC T135°C Db, IP66
(T_{amb} -20°C to 40°C)
OR
Ⓜ II 3 D Ex tc IIIC T135°C Dc, IP66
(T_{amb} -20°C to 40°C)

Combination of Gas and Dust

Marking code:
Ⓜ II 2GD Ex e IIC T3, Gb
Ex tb IIIC T135°C Db, IP66
(T_{amb} -20°C to 40°C)
OR
Ⓜ II 3GD Ex nA IIC T3 Gc
Ex tc IIIC T135°C Dc, IP66
(T_{amb} -20°C to 40°C)

Address of manufacturer

AUSTRALIA

Regal Beloit Australia Pty Ltd
19 Corporate Avenue, Rowville VIC Australia 3178
T: +61 3 9237 4040
salesAUvic@regalrexnord.com

NEW ZEALAND

Regal Rexnord New Zealand Limited
18 Jomac Place, Avondale, Auckland
T: 0800 676 722
salesNZnth@regalrexnord.com

Classification of zone, group and temperature category are in accordance with the standards applied in the certificates. A general explanation of these is available in the product catalogue.

The hazardous location motor nameplates also carry the certification number in addition to the marking codes for the specific protection levels. Details of the standards to which these are certified are available on the actual certificates, copies of which can be accessed from www.regalaustralia.com or obtained from Regal Rexnord Australia office.

NOTICE: Only motors that carry nameplates indicating Ex e or Ex nA or Ex t or combination of them can be used in hazardous locations. Check nameplate before installing motors in hazardous locations.

CAUTION! Specific conditions of use for Hazardous Area Motor:

1. The equipment may present a potential electrostatic charging hazard: the user instructions shall be followed in order to minimize the risk of electrostatic discharge.
2. For arrangements that include a separately motor driven cooling fan, these shall be tested to verify that the rating of the cooling fan motor is not exceeded.
3. The thermal protection devices, when fitted with the motors with VVVF drives, shall be connected into motor control circuit in such a manner as to disconnect the source of supply in order to prevent the nominated temperature class from being exceeded.
4. The stator RTD's and thermistors can be connected via standard industrial controller provided that the controller is located in a safe area.
5. The plug and socket type DXN1 shall not be used on inverter driven motors above 50/60Hz.
6. The plug and socket type DXN1 are limited to use within low impact areas.

7.0 CABLE ENTRIES

Cable entries are via appropriate cable glands or conduits fitted to the threaded entries in the wall of the terminal box or the gland plate attached to it. Cable entries for various frame sizes are as per the following table.

| Motor frame | No. of entries | Entry size x pitch | Reference drawing for Ex motors |
|--------------------------|-------------------|-----------------------------------------------|------------------------------------------------------------------------------------------------|
| 80 - 132 Brake Motors | 2 | M20 x 1.5 or M25 x 1.5 | B - HGA0813TBB, B - HGA0813TBB1, B - HGA0813TBB2, B - HGA0813TBB3, B - HGA0813TBB4 |
| 80 - 132 | 2 | M20 x 1.5 or M25 x 1.5 | B - HGA0813TB1 |
| 160 - 180 | 2 | M25 x 1.5 or M32 x 1.5 or M40 x 1.5 | B - HGA1618TB1, B - HGA1618TB2 |
| 200 - 280 | 2 | M32 x 1.5 or M40 x 1.5 or M50 x 1.5 | B - HGA2022TB1, B - HGA2022TB2, B - HGA2528TB1, B - HGA2528TB2 |
| 315 | Blank Gland Plate | Customer to drill to suit. Max size 2xM63x1.5 | B - HGA315TB |

Cable glands used by installer on hazardous location motors must be of IEC Ex certified type as appropriate to the installation requirements. Unused cable entries must be blanked off by installer using IEC Ex certified conduit stops as appropriate.

Cable glands and conduit stops must be of an IP Rating equal to or better than that of main motor as marked on the nameplate.

Vibration sensors and shaft encoders when fitted by the installer are to be appropriately certified by IECEx or ATEX for Zone 1 Group II T3 for Ex e, Zone 2 Group II T3 for Ex nA or Zone 21 T135oC for Ex t.

7.1 SUPPLY CABLE/ TERMINALS

Supply terminals are located in the terminal box. They are suitable for receiving crimped lugs on the supply cables. In addition the terminal box also houses an earthing terminal.

| Motor frame | Terminal Size | Max supply cable size* [mm ²] |
|-------------|---------------|--------------------------------------------|
| 80 - 132 | M5 | 16 |
| 160 - 180 | M6 | 50 |
| 200 - 225 | M8 | 95 |
| 250 - 280 | M10 | 2 x 95 |
| 315 | M12 | 2 x 185 |

* 4 or 3 core +E, PVC insulated

8.0 ELECTRICAL CONNECTION

- **WARNING!** Ensure all electrical connections are solid and continuous.
- Check motor starter and overloads for correct rating and trip setting.
- **WARNING!** All circuit breakers, HRC fuses or protective devices associated with the motor must be rated to suit motor running current and starting characteristics.
- Supply cables must be appropriately selected considering the voltage drop.
- When using long supply cables with VVVF drive, check with The manufacturer for proper recommendations to avoid high voltage transients occurring at motor terminals.
- Check the connection diagram on the motor terminal box and make sure the supply leads are properly connected considering the supply phase sequence.
- Ensure that the supply cable termination on to the motor terminal board is firm, without loss of strands while using crimped lugs and all washers are used in the correct order as provided.
- Ensure enough clearances are provided between supply cable lugs and to earth especially so in case of hazardous location motors.
- Ensure that proper earthing connection is made with all washers as provided.
- **WARNING!** Check that the cable glands used on hazardous location motors are Ex approved by the standards organisation. Gland plugs to be of approved type.
- If using conduit for the supply leads, ensure the conduit is completely threaded in and seal the threads appropriately.
- If RTDs of hazardous location motors are connected to monitor the winding temperature, the maximum voltage to the RTDs must be kept to 90V(peak) or below.
- The thermal protection devices shall be connected into the motor control circuit in such a manner as to disconnect the source of supply in order to prevent the nominated temperature class from being exceeded. The stator RTDs and thermistors can be connected via a standard industrial controller provided that the controller is located in a safe area.

9.0 INITIAL START UP

Prior to initial start-up check the following-

- Insulation resistance of motor winding to earth to be over 1 MΩ for motors up to 600V and over 10 MΩ for over 600V.
- Thermistors or RTDs if fitted, should be checked for continuity with a multimeter,
- **NOTICE:** Ensure thermistors are wired up to the motor protection relay as to trip the supply to the motor in the event of an over temperature.
- Do not megger test thermal protective devices across their terminals. Short the entire protector leads together and apply the test voltage between the shorted leads and earth and/or phases.
- **NOTICE:** Hazardous location motors supplied by a VVVF drive must have the thermal protection devices connected into the motor control circuit in such a manner as to disconnect the source of supply in the event of an over temperature thus preventing the nominated temperature class being exceeded.
- Anti-condensation heaters if provided must be so connected as to switch on when the motor supply is disconnected and switch off when the motor supply gets connected.
- Ensure that the supply voltage and frequency correspond to the motor nameplate ratings.
- Ensure shaft turns freely before initial start.
- Measure winding resistance between supply terminals and record in the log book.

10.0 OPERATION

- **WARNING!** Before running the motor make sure that the terminal box lid is closed and secured with appropriate clearance to live parts.
- **WARNING!** Make sure that appropriate earthing is done.
- If an earthing ring and earth brush are provided, make sure that the earthing ring is clean and the earth brush makes a good contact with the earthing ring.
- **WARNING!** Make sure that the coupling and/or transmission is adequately guarded for safety.
- Check the mounting bolts and/or flanges are firmly secured.
- **WARNING!** Make sure of no loose objects around that may be sucked by the cooling fan on the motor.
- **NOTICE:** Make sure that the load applied is within the nameplate specification.
- Make sure that the ambient temperature is inside 40°C or nameplate specification.
- Avoid frequent starting of motor. Contact the manufacturer for recommendation on frequency and duration of starts.
- If a VVVF drive is used on Ex nA motor, make sure that the applied load is inside the limits specified by the loadability curve shown on page 9.
- On Ex e motors, make sure that the starting method employed keeps the starting current and duration within the nameplate figures of IA/IN ratio and tE time.

- Check that the running current on no load and full load are reasonably balanced within 10% of the average and record the figures in the log book for future reference. Note that the current imbalance can be higher, typically 10 times the voltage imbalance if there is an imbalance in supply voltage.
- Brake motors used in hazardous locations must have a limited number of repeat stops to 20 per hour.

10.1 NUMBER OF STARTS PER HOUR

The number of starts per hour is dependant on the inertia of the driven load and the load torque demand. When high inertia load is applied (flywheel, heavy fan etc) contact The manufacturer for recommendations. A guide to generally acceptable starts per hour would be as per table.

For greater number of starts per hour, please contact The manufacturer for advice.

| Frame | Starts per hour | | | |
|-------|-----------------|--------|--------|--------|
| | 2 Pole | 4 Pole | 6 Pole | 8 Pole |
| 80* | 20 | 40 | 40 | - |
| 90* | 16 | 30 | 40 | - |
| 100* | 16 | 30 | 40 | 40 |
| 120* | 16 | 30 | 40 | 40 |
| 132* | 10 | 20 | 25 | 25 |
| 160 | 10 | 20 | 25 | 25 |
| 180 | 8 | 15 | 20 | 20 |
| 200 | 6 | 12 | 12 | 12 |
| 225 | 5 | 10 | 10 | 10 |
| 250 | 4 | 8 | 8 | 8 |
| 280 | 3 | 6 | 6 | 6 |
| 315 | 3 | 4 | 4 | 4 |

*20 Starts / Hour for Ex t brake motors

10.2 PERMITTED STARTING TIME

In respect to the temperature rise of the motor, starting time (i.e., from rest to operational speed) should not exceed the time indicated in the following table. Motor must be allowed to cool prior to each start.

NOTE: For Ex e motors t_E time stated on motor name plate takes precedence over these times

| Frame | Starting Method | Maximum starting time [sec] | | | |
|-----------|-----------------|-----------------------------|--------|--------|--------|
| | | 2 Pole | 4 Pole | 6 Pole | 8 Pole |
| 80 | D.O.L | 15 | 26 | 40 | - |
| 90 | D.O.L. | 10 | 15 | 25 | - |
| 100 | D.O.L. | 12 | 13 | 18 | 40 |
| 112 | D.O.L. | 10 | 10 | 18 | 35 |
| 132 | D.O.L. | 14 | 12 | 12 | 25 |
| 160 - 315 | D.O.L. | 15 | 15 | 20 | 20 |
| 160 - 315 | Star-delta | 45 | 45 | 60 | 60 |

11.0 MAINTENANCE

Reliable, trouble free operation of a motor needs regular

maintenance. Exact maintenance needs vary based on the site conditions. To obtain reliable service from the motor, the following maintenance schedule may be used as a guide. An authorised service agent must carry out maintenance of hazardous location motors HGAE, HGAN or HGAD. Clean the surface of the motor with a damp cloth to minimise the risk of electrostatic discharge.

- A. Ensure air intake space is unobstructed.
- B. On a weekly basis use an air hose to ensure all air ways are clear and free of dust.
- C. Once every month, check motor for condensation. Replace drain plugs before starting if they are blocked or found missing.
- D. Do not wash the motor down unless it is IP66 rated.
- E. On a quarterly basis-
 - Check the motor terminals for tightness and proper contact.
 - If terminal lug/s are discoloured, re-terminate with fresh lugs.
 - Check operation of starting equipment, ensuring all terminations are tight.
 - Check mechanical operation of thermal overload relays, if any.
 - Check mechanical operation of thermistor relays, if fitted.
 - Check operation of anti-condensation heaters, if fitted.
 - Check the earthing ring and earth brush length if fitted.
- F. On a six monthly basis, in addition to the items in 'E'
 - Check winding resistance between supply terminals and compare to original value and enter in log book.
 - Check supply voltage at motor terminals and record in log book.
 - Check bearings for abnormal noise/overheating.
- G. On an annual basis, in addition to the items in 'E' and 'F'
 - Re-grease the bearings as recommended in the following table. Frames 71-180 use sealed bearings. Frames 200-315 use open re-greasable bearings. When re-greasing bearings ensure that the correct type of grease is used. If in doubt about the existing grease type, clean out the old grease thoroughly from bearings and bearing housings, prior to regreasing.

NOTICE: NEVER MIX GREASE OF DIFFERENT TYPES Use lithium based grease such as Shell Alvania®* R3 or equivalent unless otherwise specified. HGAH, HGASS and HGAHS motors require extra high temperature grease such as Magnalube G®* or equivalent.

- Completely disassemble stator, rotor apart and clean thoroughly.
- Check bearings for wear/damage – replace as necessary.
- Check all bolts and nuts for cracks or damage – replace as necessary.
- Check all holding down bolts for signs of fatigue or damage – replace as necessary.
- After re-assembly, check and record in the log book - Insulation resistance by megger
No load current and voltages
Full load current and voltages
Ensure that these figures compare well with the original records in the log book.
- Check and ensure that the cooling fan is operational.

12.0 SEALED BEARINGS

The required replacement interval for sealed bearings is generally determined by the grease life which is dependant on operating temperature, operating speed, the limiting speed of the bearing and the type of grease. Under normal operating conditions the following relationship applies:

$$\log t = 6.54 - 2.6 \frac{n}{N} - (0.025 - 0.012 \frac{n}{N}) T$$

Where:

t = Average grease life (hours)

n = Speed (RPM)

N = Bearing limiting speed with grease lubrication (RPM)

T = Operating temperature (°C)

For further information, please contact the manufacturer for advice.

12.1 OPEN (REGREASABLE) BEARINGS

It should be noted that for motors fitted with Ball and Roller bearings, the lubrication intervals for both bearings should be based on the roller bearing data.

The re-lubrication intervals recommended are calculated on the basis of normal working conditions.

CAUTION! Under arduous conditions please contact The manufacturer or the bearing manufacturer's catalogue. Air operated grease guns should not be used.

Replenishment of grease media should be by means of a hand held grease gun whilst motor is running with relief plate removed.

*Alvania and Shell are believed to be the trademarks of Shell Oil Company Corporation and are not owned or controlled by Regal Rexnord Corporation.

*Magnalube-G is believed to be a trademark of General Magnaplate Corporation and is not owned or controlled by Regal Rexnord Corporation.

Recommended Grease Replenishment Intervals (Hours) 1)

| Bearing number ²⁾ | Bearing bore [mm] | Qty of grease [g] | 3000 r/min | | 1500 r/min | | 1000 r/min | | 750 r/min | |
|------------------------------|-------------------|-------------------|------------|--------|------------|--------|------------|--------|-----------|--------|
| | | | Ball | Roller | Ball | Roller | Ball | Roller | Ball | Roller |
| 6312/NU312 | 60 | 20 | 3800 | 1900 | 10100 | 5050 | 16000 | 8000 | 20000 | 10800 |
| 6313/NU313 | 65 | 25 | 3400 | 1700 | 9400 | 4700 | 15100 | 7500 | 20000 | 10300 |
| 6314/NU314 | 70 | 30 | 3000 | 1500 | 8800 | 4400 | 14300 | 7150 | 19500 | 9750 |
| 6315/NU315 | 75 | 30 | 2570 | 1285 | 8200 | 4100 | 13500 | 6750 | 18500 | 9250 |
| 6316/NU316 | 80 | 35 | 2200 | 1100 | 7600 | 3800 | 12800 | 6400 | 17700 | 8850 |
| 6317/NU317 | 85 | 40 | 1800 | 900 | 7100 | 3550 | 12100 | 6050 | 16800 | 8400 |
| 6318/NU318 | 90 | 45 | 1650 | 825 | 6600 | 3300 | 11500 | 5750 | 16000 | 8000 |
| 6319/NU319 | 95 | 45 | 1500 | 750 | 5700 | 2850 | 9000 | 4500 | 14600 | 7300 |

¹⁾ Based on maximum grease service life of 20,000 hours

²⁾ Refer to Nameplate / Motor to confirm bearing size.

12.2 LOADABILITY CURVE FOR VVVF DRIVE

NOTICE:

1. Applied load on the motor shall be inside the limits for the loadability curve for the motor. The Standard loadability curve is shown below. In special circumstances, determined by Regal Rexnord Engineering, the limits on the curve may be extended.* In either case the limits of operation are specified on the motor PWM Converter Supply nameplate.
2. HGA Ex nA motors are suitable for operation with PWM converters (VVVF drives) with carrier frequency >5kHz or default switching frequency of the drive whichever is lower.
3. When motors are operated below 50Hz with variable torque loads, a de-rating factor is to be applied as per the solid line (curves 1 & 3) of the loadability curve.
4. When motors are operated below 25Hz with constant torque loads (curve 2) forced ventilation by separately driven cooling fan is required. Alternatively, permissible maximum torque at lower frequencies is to be determined by test for self cooled motors. In special circumstances the lower limit of operation may be a frequency less than 25Hz. This will be specified on the motor PWM Converter Supply nameplate.
5. At frequencies above 50Hz the motors are suitable for operation at constant power up to the maximum frequency shown on the nameplate (curves 4 & 5). All motors are suitable for operation up to 60Hz. Maximum frequency is specified on the nameplate.
6. These motors supplied by VVVF drives must be fitted with thermal protection devices, such as thermistors in winding, which shall be connected to the motor control circuit in such a manner as to prevent the nominated temperature class from being exceeded.

*Extended Limits on loadability curve for the motor may be calculated or determined by testing. Testing is performed subject to charges.

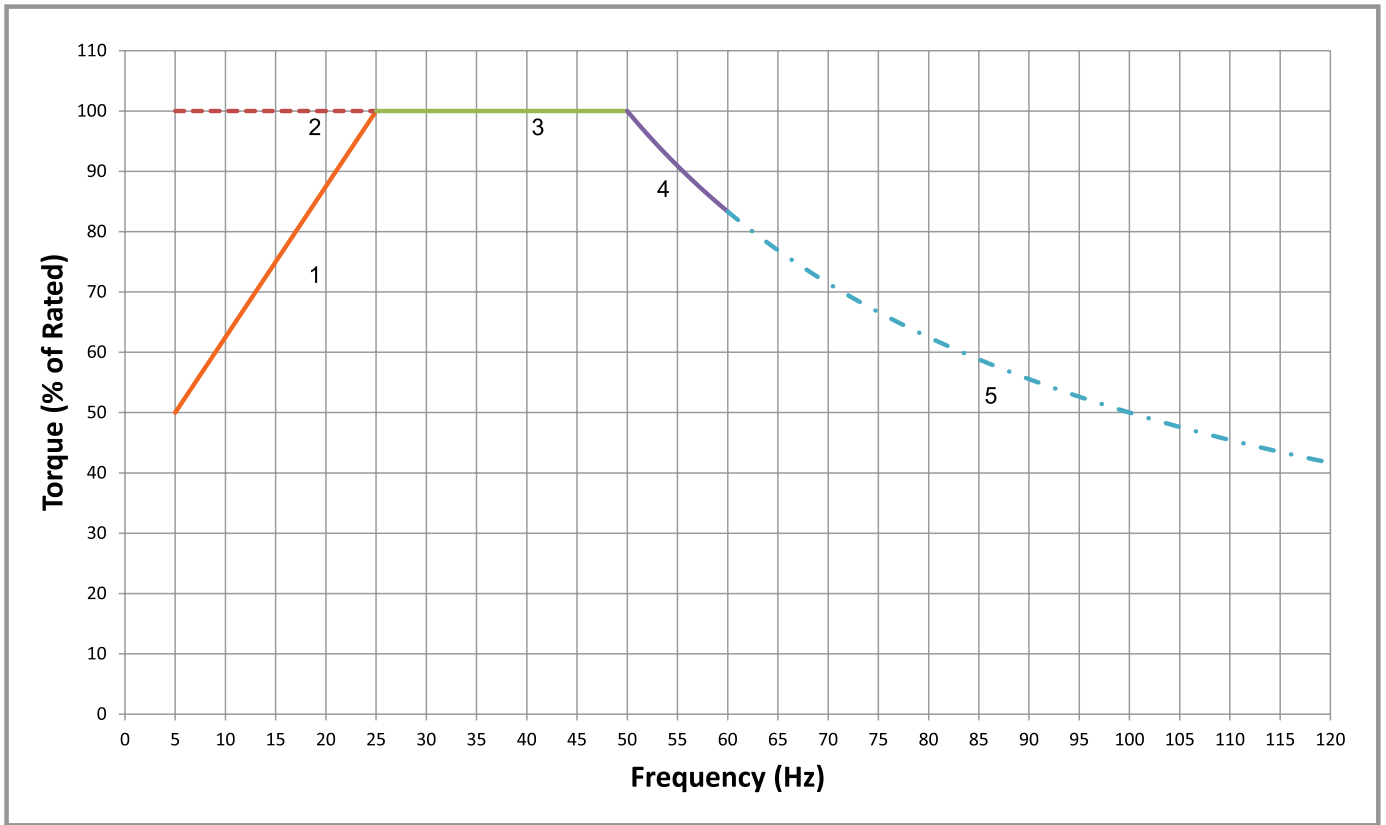

- **(1) Reduced Torque** (with Standard Cooling Fan)
- - - **(2) Constant Torque** (With Separately Driven Cooling Fan)
- **(3) Constant Torque** (25 - 50Hz)
- **(4) Constant Power** (50 - 60Hz)
- · - · **(5) Constant Power** (up to Maximum Operating Frequency)

EU Declaration of Conformity

We of Regal Beloit Australia Pty Ltd.
19 Corporate Avenue
Rowville
Victoria Australia 3178

declare that the product:

Product name 3 Phase cage induction motor **Model:**

Series SGA in frame sizes 71 to 315 and HGA in frame sizes 80 to 315 **Ser. No:**

is approved by SGS Fimko Oy [Sarkiniementie 3, P.O.Box 30, FI-00211, Helsinki, Finland, Notified Body No.: NB 0598 under the certificate numbers:

| Certificate Number | Standards Applied |
|---------------------|-----------------------------------------------------|
| Baseefa 14ATEX0030X | EN 60079-0:2012; EN 60079-7:2007; EN 60079-31:2013 |
| Baseefa 14ATEX0031X | EN 60079-0:2012; EN 60079-15:2010; EN 60079-31:2013 |

and conforms to the following European Directive including EH&SR requirements:

ATEX 2014/34/EU of 26 February 2014



The product is also in conformity with:

EMC Directive 2014/30/EU, regarding the intrinsic characteristics to emission and immunity levels in conformity with EN 60034-1.

By design, the machines, considered as components, comply with the essential requirements of

Machinery Directive 2006/42/EC, which provides that the installation and operation of the machines is to be realised in compliance with the operating instructions and IEC 60204-1.

Declaration of Incorporation

The machines must not be put into service until the machinery into which they have been incorporated has been declared in conformity with the Machinery Directive.

Note: The Low Voltage Directive 2014/35/EU is not applicable to ATEX products since covered by ATEX Directive 2014/34/EU

To ensure that this equipment meets the requirements of all the above, the product must be installed, used and maintained in accordance with the supplied Installation, Operation and Maintenance Instruction manual.

Signed by 
Tim Makris

Title Operations Director

Date 16 Feb 2022





Industrial Systems Regal Rexnord

HEAD OFFICE - AUSTRALIA

Regal Beloit Australia Pty Ltd
ABN 61 122 303 084
19 Corporate Ave (PO Box 2340)
Rowville VIC 3178, Australia
Customer Service: 1300 888 853
T: +61 3 9237 4040
F: +61 3 9237 4050
salesAUvic@regalrexnord.com
www.regalaustralia.com.au

NEW ZEALAND

Regal Beloit New Zealand Limited
18 Jomac Place Avondale
Auckland, New Zealand
T: 0800 676 722
F: +64 9 820 8504

PRESENT IN

CHRISTCHURCH
ROTORUA
T: 0800 676 722

STATE OFFICES

VICTORIA

19 Corporate Avenue
Rowville VIC 3178
T: 1300 888 853
F: +61 3 9237 4050

NEW SOUTH WALES

8 Bushells Place
Wetherill Park NSW 2164
T: 1300 888 853
F: +61 2 8781 3131

QUEENSLAND

7 Mahogany Court
Willawong QLD 4110
T: 1300 888 853
F: +61 7 3246 3210

PRESENT IN

MACKAY
SOUTH AUSTRALIA
WESTERN AUSTRALIA
T: 1300 888 853

The following trademarks are not owned or controlled by Regal Rexnord Corporation: Alvania and Shell, Shell Oil Company Corporation, Magnalube-G, General Magnaplate Corporation.

"Regal Rexnord" is not indicative of legal entity. Refer to product purchase documentation for the applicable legal entity.

Regal Rexnord and Marathon are trademarks of Regal Rexnord Corporation or one of its affiliated companies.

©2018, 2020, 2023 Regal Rexnord Corporation, All Rights Reserved. MCIM23038E • Form# SB0076E

