



INDUSTRIAL SLA SERIES MOTOR

CAST ALUMINIUM MULTI-MOUNT THREE PHASE MOTORS
SIZES 56 - 160, 0.09 - 18.5KW

DECEMBER 2022 | Australia and New Zealand

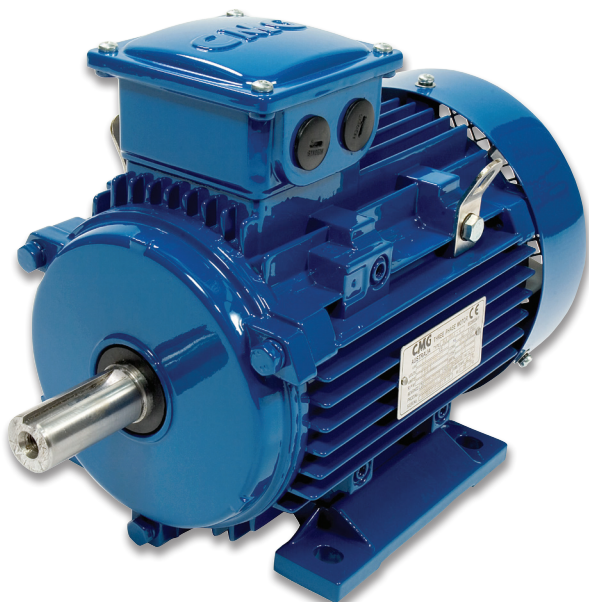
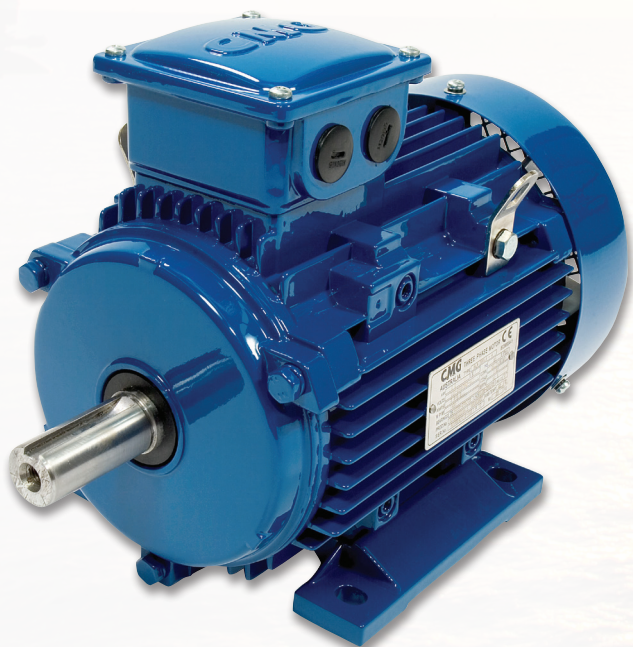

TABLE OF CONTENTS

INTRODUCTION	page 2
PART NUMBER LOGIC	page 3
PERFORMANCE DATA	pages 4 - 5
DIMENSIONAL DRAWINGS	pages 6 - 8
MODIFICATIONS AND VARIATIONS	page 9



MARATHON® SLA SERIES

CAST ALUMINIUM MULTI-MOUNT THREE PHASE MOTORS
SIZES 56 - 160, 0.09 - 18.5KW

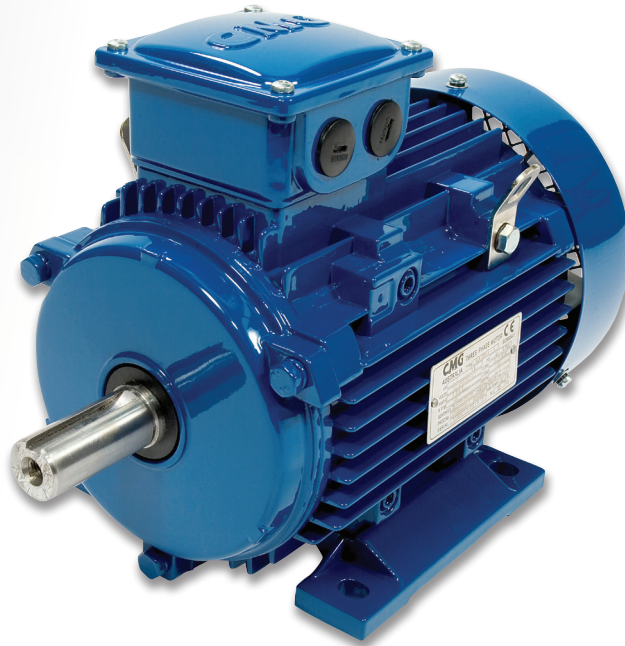

Our Marathon SLA Series Motor range is built in an all aluminium frame which has the same enhanced performance and electrical design as the cast iron SGA Series which has been specified by Australian industry for over a decade.

STANDARDS AND SPECIFICATIONS

The main dimensions and rated outputs of the SLA series generally conform to International Standards IEC 60034 and IEC 60072, and Australian Standard AS1359.

MULTI-MOUNT FEATURE

The standard SLA motor is supplied with the terminal box top mounted, and has detachable feet. The unique multi-mount design allows the motor feet to be removed and the motor mounted from any of the 16 mounting pads. This feature means that for axial flow fans, there is no need for a motor mount in the fan case, which enables quicker assembly times, lower cost and less restriction to air flow.

Alternatively the feet may be relocated to either side, for a wall mounted motor or side mounted terminal box.

OPERATING PARAMETERS

Standard SLA series motors are designed with the following parameters:

- Continuous duty (S1)
- Three phase 380-420V, 50Hz power supply
- Ambient temperatures up to 40°C
- Installation at altitudes up to 1000 metres

Performance data is based on these parameters and may need adjustment for different requirements.

F CLASS INSULATION, B CLASS TEMPERATURE RISE

SLA series motors have class F insulation and class B temperature rise which gives them good service factor capabilities.

DEGREE OF PROTECTION

Standard level of enclosure protection for the SLA series is IP 55, with increased ratings available on request.

PUMP APPLICATION

A locked drive end bearing is standard on all SLA flange mounted motors from 90 to 160 frame. This makes it perfect for pump applications where minimal axial shaft movement is critical to provide tight tolerances for impellers. On request Regal Rexnord Australia can provide a locked bearing option for smaller frame sizes and foot mounted motors.

AIR MOVEMENT APPLICATION

Low weight design and the standard drilled and tapped hole in the shaft makes the SLA series ideally suited for all air movement applications.

EFFICIENCY

SLA motors exceed requirements of European Eff2. For Eff1 aluminium frame motors, refer to Regal Rexnord Australia's HLA series catalogue.

PAINT FINISH

Motors are painted with a high quality enamel finish. The standard colour is dark blue (RAL5010), with other colours available on request.

BEARINGS

Bearings fitted are a deep groove ball type with double seals and are the same size for both ends.

Motor frame	Bearing Size
56	6201-2RS
63	6201-2RS
71	6202-2RS
80	6204-2RS
90S/L	6205-2RS
100L	6206-2RS
112M	6206-2RS
132S/M	6208-2RS
160M/L	6309-2RS

TERMINAL BOX

The terminal box of the SLA series is separate from the body of the motor allowing it to be rotated providing ease of connection to supply.

INTERNAL CONNECTIONS, VOLTAGES AND VF DRIVE SELECTION

Standard terminal connections for motors 3kW and below is 240V Delta / 415V Star. These motors are suitable for operation with 240V three phase Variable Frequency Drives or 415V DOL starting.

Standard terminal connections for motors 4kW and above is 415V Delta / 720V Star. These motors are suitable for operation with 415V three phase Variable Frequency Drives, 415V Star/Delta or 415V DOL starting

PART NUMBER LOGIC

When placing an order the motor product code should be specified. The product code of the motor is composed in accordance with the following example:

M	3	2	0	0	1	5	0	3	S	L	A	1
1	2	3	4-8				9	10 - 12		13		

POSITION 1

M= metric frame size

POSITION 2

Phase

3 = Three phase

A = 2 speed fan duty single winding

B = 2 speed fan duty separate windings

POSITION 3

Number of poles

2 = 2 poles

4 = 4 poles

6 = 6 poles

8 = 8 poles

E = 2/4 poles

J = 4/6 poles

K = 4/8 poles

N = 6/8 poles

P = 6/12 poles

S = 8/16 poles

POSITIONS 4 TO 8

Rated power output

(kW x 100)

(refers to high speed for 2 speed motors)

POSITION 9

Mounting arrangements

3 = B3

4 = B3/B5

5 = B5

6 = B3/B14A

7 = B14A

8 = B3/B14B

9 = B14B

0 = Body mount

POSITIONS 10 TO 12

Series

SLA = SLA series

POSITION 13

Variation suffix

Blank = standard

1 = high output design

F = flying leads

H = H class insulation

P = pad mount (fitted pads)

R = airstream rated



PERFORMANCE DATA

SLA SERIES, THREE PHASE, 380-420V 50HZ

IP55, F CLASS INSULATION, B CLASS TEMPERATURE RISE

Motor Frame	kW	Speed [r/min]	415V 50Hz								380V 50Hz	400V 50Hz	Moment of inertia $J=1/4GD^2$ [kg m ²]	Weight of foot mount motor [kg]
			Efficiency %	Power factor Cos ϕ	Current		Torque			Current	Current			
					Full load I_N [A]	Locked rotor I_L/I_N	Full load T_N [Nm]	Locked rotor T_L/T_N	Break down T_B/T_N	Full load I_N [A]	Full load I_N [A]			
3000 R/MIN = 2 POLES														
56B	-9	0.12	2730	64.0	0.79	0.33	5.2	0.42	2.3	2.4	0.36	0.34	0.0001	3.6
63A	-11	0.18	2730	65.0	0.79	0.51	5.5	0.63	2.6	2.6	0.56	0.53	0.00015	4.5
63B	-11	0.25	2800	69.0	0.81	0.64	5.5	0.85	2.2	2.3	0.70	0.66	0.00018	4.7
71A	-14	0.37	2800	71.0	0.81	0.93	6.1	0.93	2.2	2.3	1.02	0.96	0.00035	6.0
71B	-14	0.55	2800	74.0	0.82	1.35	6.1	1.35	2.2	2.3	1.47	1.40	0.00045	6.3
80A	-19	0.75	2820	76.0	0.84	1.61	6.1	2.5	2.8	4.0	1.76	1.67	0.00075	10
80B	-19	1.1	2835	78.5	0.86	2.3	5.9	3.7	2.7	3.0	2.5	2.4	0.0009	11
90S	-24	1.5	2860	80.5	0.85	3.0	6.7	5.0	2.9	3.5	3.3	3.1	0.0012	13
90L	-24	2.2	2830	81.8	0.87	4.3	6.4	7.4	2.8	2.8	4.7	4.5	0.0014	14
100L	-28	3	2870	83.3	0.88	5.7	7.5	10.0	2.8	3.4	6.2	5.9	0.0029	25
112M	-28	4	2900	86.1	0.89	7.4	7.9	13.2	2.7	3.5	8.0	7.6	0.0055	28
112MB	-28	5.5 ¹⁾	2890	86.4	0.89	9.9	7.8	18.2	2.8	3.4	11.0	10.0	0.0055	31
132SA	-38	5.5	2925	86.8	0.87	10.2	7.0	18.0	2.4	2.3	11.1	10.6	0.0109	40
132SB	-38	7.5	2895	87.0	0.91	13.3	7.2	24.7	2.1	2.8	14.5	13.8	0.0126	45
132MB	-38	11 ¹⁾	2900	88.8	0.92	18.8	7.3	36.2	2.0	2.9	21.0	20.0	0.0145	51
160MA	-42	11	2935	88.4	0.89	19.6	7.0	35.8	2.2	2.9	21.4	20.3	0.0377	69
160MB	-42	15	2940	89.8	0.91	25.4	7.2	48.7	1.8	2.6	27.7	26.4	0.0499	78
160L	-42	18.5	2930	90.4	0.91	31.4	7.3	60.0	2.3	2.9	34.3	32.6	0.055	80
1500 R/MIN = 4 POLES														
56B	-9	0.09	1330	62.0	0.69	0.29	3.4	0.65	2.7	2.7	0.32	0.30	0.0001	3.6
63B	-11	0.18	1360	62.0	0.73	0.57	4.4	1.26	2.1	2.2	0.62	0.59	0.0003	4.7
71A	-14	0.25	1370	67.3	0.74	0.73	5.2	1.74	2.1	2.2	0.80	0.76	0.0008	6.0
71B	-14	0.37	1375	72.2	0.69	1.05	4.5	2.6	3.3	2.7	1.15	1.09	0.001	6.3
80A	-19	0.55	1390	72.1	0.75	1.4	4.8	3.8	2.5	2.6	1.53	1.45	0.0018	10
80B	-19	0.75	1405	75.7	0.76	1.8	5.0	5.1	2.4	2.5	2.0	1.90	0.0021	11
90S	-24	1.1	1410	77.4	0.78	2.5	5.4	7.4	2.8	2.4	2.8	2.6	0.0023	13
90L	-24	1.5	1405	79.4	0.85	3.2	5.7	10.2	1.8	2.4	3.4	3.3	0.0027	14
100LA	-28	2.2	1430	82.6	0.83	4.5	6.6	14.7	2.8	3.5	4.9	4.7	0.0054	23
100LB	-28	3	1425	82.6	0.85	4.8	8.3	20.1	2.9	3.1	5.2	4.9	0.0067	25
112M	-28	4	1445	85.3	0.82	7.9	7.6	26.4	3.1	3.5	8.6	8.2	0.0095	28
112MB	-28	5.5 ¹⁾	1425	85.8	0.85	10.9	7.3	36.9	3.2	3.3	11.9	11.3	0.0095	32
132S	-38	5.5	1450	87.0	0.85	10.4	6.8	36.2	2.3	3.1	11.3	10.8	0.0214	45
132M	-38	7.5	1450	88.1	0.87	13.7	7.5	49.4	2.6	2.9	15.0	14.2	0.0296	55
132MB	-38	11 ¹⁾	1440	89.2	0.83	21.0	7.8	72.5	1.9	3.0	22.9	21.8	0.0363	61
160M	-42	11	1460	89.2	0.85	20.0	6.9	71.9	2.0	2.8	21.8	20.8	0.0747	76
160L	-42	15	1465	90.2	0.86	27.2	7.2	98.0	2.3	2.9	29.7	28.2	0.0918	90

1) High output design – output is one kW size higher than the basic CENELEC design.
This data is provided for guidance only, guaranteed only when confirmed by Regal Rexnord Australia.

PERFORMANCE DATA

SLA SERIES, THREE PHASE, 380-420V 50HZ

IP55, F CLASS INSULATION, B CLASS TEMPERATURE RISE

Motor Frame	kW	Speed [r/min]	415V 50Hz								380V 50Hz	400V 50Hz	Moment of inertia $J=\frac{1}{4}GD^2$ [kg m ²]	Weight of foot mount motor [kg]
			Efficiency %	Power factor Cos ϕ	Current		Torque			Current	Current			
					Full load I_N [A]	Locked rotor I_L/I_N	Full load T_N [Nm]	Locked rotor T_L/T_N	Break down T_B/T_N	Full load I_N [A]	Full load I_N [A]			
1000 R/MIN = 6 POLES														
71B	-14	0.25	900	60.0	0.68	0.88	4.0	2.65	1.9	2.0	0.96	0.91	0.0009	6.3
80A	-19	0.37	915	67.5	0.70	1.08	3.4	3.9	1.8	2.1	1.18	1.12	0.0016	10
80B	-19	0.55	925	68.6	0.66	1.60	3.3	5.7	1.4	2.1	1.75	1.66	0.0019	11
90S	-24	0.75	935	74.4	0.72	1.90	4.6	7.7	2.4	2.6	2.1	2.0	0.0029	13
90L	-24	1.1	930	75.6	0.77	2.7	4.5	11.3	2.3	2.4	3.0	2.8	0.0035	14
100L	-28	1.5	950	77.7	0.73	3.7	5.1	15.1	2.2	3.0	4.0	3.8	0.0069	23
112M	-28	2.2	945	80.2	0.76	5.0	5.6	22.2	2.7	3.0	5.5	5.2	0.0140	25
132S	-38	3	970	84.6	0.77	6.4	6.7	29.5	2.3	3.2	7.0	6.6	0.0286	42
132MA	-38	4	965	84.5	0.77	8.5	6.7	39.6	2.5	3.2	9.3	8.8	0.0357	45
132MB	-38	5.5	965	85.6	0.81	11.0	6.9	54.4	2.4	3.0	12.0	11.4	0.0449	55
160M	-42	7.5	970	88.4	0.76	15.5	6.0	74.0	2.2	2.6	16.9	16.1	0.0881	78
160L	-42	11	970	89.3	0.79	23.6	5.8	108	2.2	2.4	25.8	24.5	0.2070	90
750 R/MIN = 8 POLES														
90S	-24	0.37	690	62.8	0.61	1.35	4.0	5.1	1.8	1.9	1.47	1.40	0.0042	13
90L	-24	0.55	690	63.5	0.61	2.08	4.0	7.6	1.8	2	2.3	2.2	0.0061	14
100LA	-28	0.75	700	71.0	0.67	2.28	4.0	10.2	1.8	2	2.5	2.4	0.0090	23
100LB	-28	1.1	710	72.0	0.63	3.4	4.2	14.8	2.3	2.8	3.7	3.5	0.0110	25
112M	-28	1.5	705	77.6	0.67	4.0	4.4	20.3	2.1	2.6	4.3	4.1	0.0245	28
132S	-38	2.2	715	81.5	0.74	5.1	5.3	29.4	2.1	3.0	5.6	5.3	0.0314	45
132M	-38	3	715	83.0	0.74	6.7	5.6	40.0	2.3	3.0	7.3	7.0	0.0395	55
160MA	-42	4	720	85.6	0.74	8.9	6.1	53.0	2.4	3.3	9.7	9.2	0.0753	68
160MB	-42	5.5	715	86.5	0.77	11.6	5.7	73.5	2.1	2.9	12.7	12.0	0.0931	78
160L	-42	7.5	715	86.9	0.79	15.4	5.8	100	2.3	2.9	16.8	16.0	0.1260	90

This data is provided for guidance only, guaranteed only when confirmed by Regal Rexnord Australia.

DIMENSIONAL DRAWINGS

FOOT MOUNT B3 (IM1001)

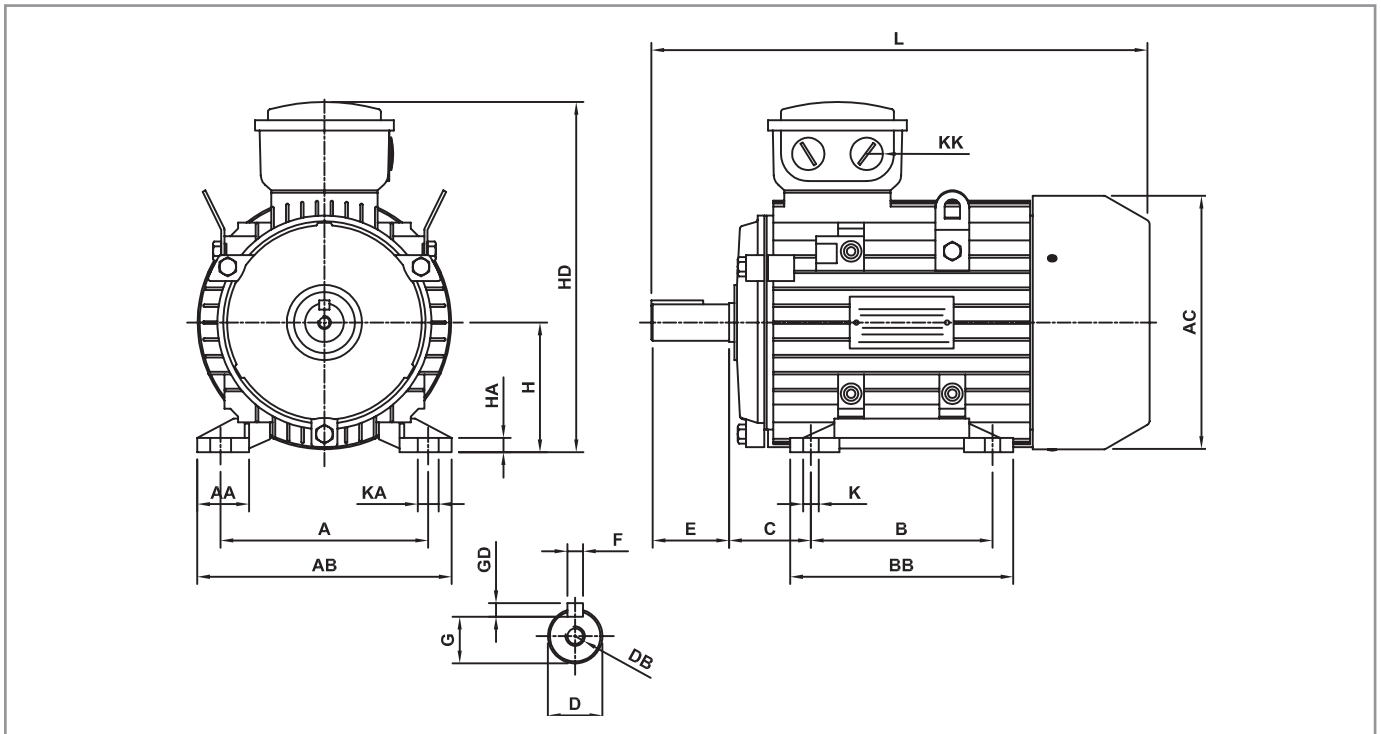

FOOT MOUNT B3 (IM1001)

Motor frame	A	AA	AB	AC	B	BB	C	D	DB	E	F	GD	G	H	HA	HD	K	KA	KK	L	
56	-9	90	23	112	114	71	88	36	9	M4	20	3	3	7.2	56	8	165	5.8	8	1xM20	198
63	-11	100	24	123	120	80	100	40	11	M4	23	4	4	8.5	63	7	186	7	9.5	1xM20	220
71	-14	112	26	137	137	90	110	45	14	M5	30	5	5	11	71	8	201	7	11	1xM20	244
80	-19	125	35	157	158	100	125	50	19	M6	40	6	6	15.5	80	9	225	10	14	1xM20	289
90S	-24	140	37	173	178	100	125	56	24	M8	50	8	7	20	90	10	247	10	14	2xM20	313
90L	-24	140	37	173	178	125	150	56	24	M8	50	8	7	20	90	10	247	10	14	2xM20	338
100L	-28	160	40	197	198	140	172	63	28	M10	60	8	7	24	100	12	270	12	16	2xM20	384
112M	-28	190	41	227	221	140	180	70	28	M10	60	8	7	24	112	12	304	12	16	2xM25	402
132S	-38	216	51	262	260	140	186	89	38	M12	80	10	8	33	132	15	343	12	16	2xM25	485
132M	-38	216	51	262	260	178	224	89	38	M12	80	10	8	33	132	15	343	12	16	2xM25	518
160M	-42	254	55	304	314	210	260	108	42	M16	110	12	8	37	160	18	420	15	18	2xM32	605
160L	-42	254	55	304	314	254	304	108	42	M16	110	12	8	37	160	18	420	15	18	2xM32	650

DIMENSIONAL DRAWINGS

LARGE FLANGE MOUNT B5 (IM3001)

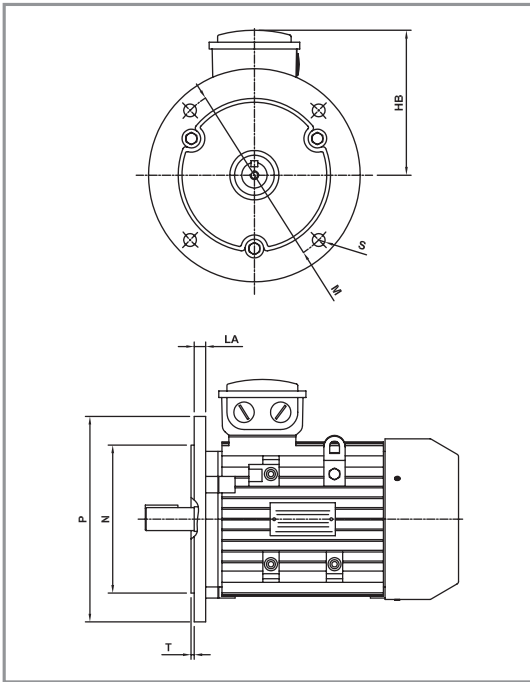

FLANGE MOUNT B5 (IM3001)

Motor frame	HB	LA	M	N	P	S	T	
56	-9	109	8	100	80	120	7	3.0
63	-11	123	10	115	95	140	10	3.0
71	-14	130	10	130	110	160	10	3.5
80	-19	145	12	165	130	200	12	3.5
90S	-24	157	12	165	130	200	12	3.5
90L	-24	157	12	165	130	200	12	3.5
100L	-28	170	14	215	180	250	15	4.0
112M	-28	192	14	215	180	250	15	4.0
132S	-38	211	14	265	230	300	15	4.0
132M	-38	211	14	265	230	300	15	4.0
160M	-42	260	15	300	250	350	19	5.0
160L	-42	260	15	300	250	350	19	5.0

SMALL FLANGE (FACE) B14 (IM3601)

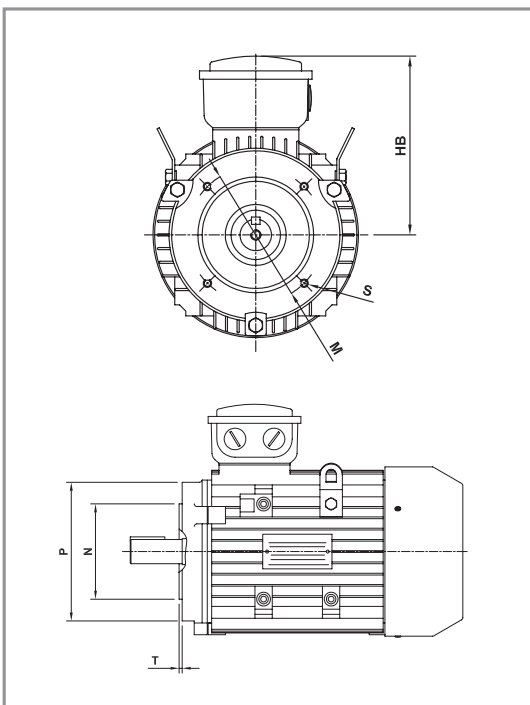

FACE MOUNT B14A (IM3601)

Motor frame	HB	M	N	P	S	T	
56	-9	109	65	50	80	M5	2.5
63	-11	123	75	60	90	M5	2.5
71	-14	130	85	70	105	M6	2.5
80	-19	145	100	80	120	M6	3.0
90S	-24	157	115	95	140	M8	3.0
90L	-24	157	115	95	140	M8	3.0
100L	-28	170	130	110	160	M8	3.5
112M	-28	192	130	110	160	M8	3.5
132S	-38	211	165	130	200	M10	3.5
132M	-38	211	165	130	200	M10	3.5
160M	-42	260	215	180	250	M12	4.0
160L	-42	260	215	180	250	M12	4.0

FACE MOUNT B14B (IM3601)

Motor frame	HB	M	N	P	S	T	
56	-9	109	85	70	105	M6	2.5
63	-11	123	85	70	105	M6	2.5
71	-14	130	115	95	140	M8	3.0
80	-19	145	130	110	160	M8	3.5
90S	-24	157	130	110	160	M8	3.5
90L	-24	157	130	110	160	M8	3.5
100L	-28	170	165	130	200	M10	3.5
112M	-28	192	165	130	200	M10	3.5
132S	-38	211	215	180	250	M12	4.0
132M	-38	211	215	180	250	M12	4.0
160M	-42					available on request	
160L	-42					available on request	

For further dimensional data, contact Regal Rexnord Australia.

DIMENSIONAL DRAWINGS

MULTI-MOUNT OPTION - SLA

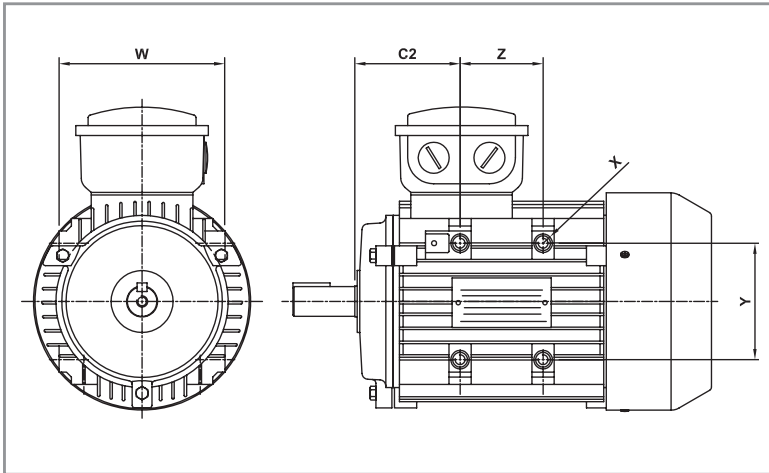

MULTI-MOUNT B0

Motor frame	C2	W	XÉ	Y	Z	
56	-9	55	84	M5	64	32
63	-11	62.5	94	M5	70	35
71	-14	71	109	M6	78	38
80	-19	79	122	M8	88	42
90S	-24	85	134	M8	94	42
90L	-24	85	134	M8	94	67
100L	-28	94	154	M8	110	78
112M	-28	104	170	M10	120	72
132S	-38	123	206	M10	154	72
132M	-38	123	206	M10	154	110
160M	-42	153	250	M12	190	120
160L	-42	153	250	M12	190	164

¹⁾ 16 multi-mount mounting pads, 12 tapped or have a provision for tapping. The standard multi-mount offers mounting holes that are vertical or horizontal only.

PAD MOUNT - SLAP

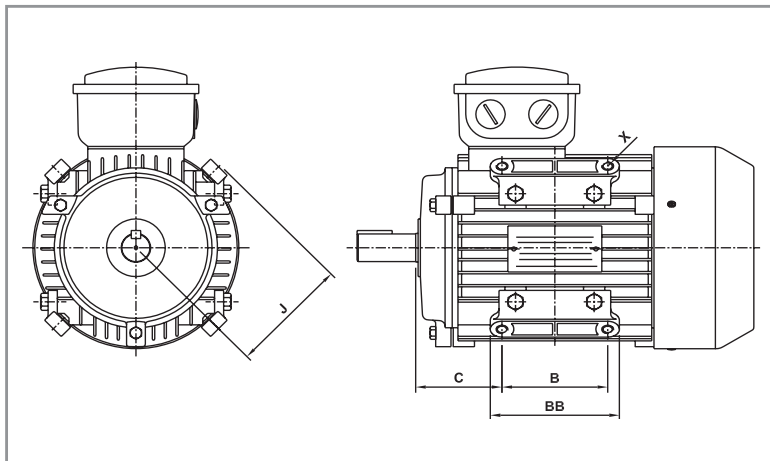

MULTI-MOUNT B0

Motor frame	B	BB	C	J	X	
71	-14	71	89	55	82	M10
80	-19	90	110	55	97	M12
90S	-24	90	110	61	100	M12
90L	-24	90	110	73.5	100	M12
100L	-28	100	120	83	114	M12
112M	-28	100	120	90	125	M12
132S	-38	102	132	108	158	M16
132M	-38	140	170	108	158	M16
132S	-38	102	132	108	158	M16
132M	-38	140	170	108	158	M16
160M	-42					available on request
160L	-42					available on request

Pad mount motors are supplied by fitting 4 pads to the multi-mount motors. This option enables the mounting brackets to be fitted in a radial position relative to the motor shaft.

AIRSTREAM RATED PAD MOUNT - SLAPR

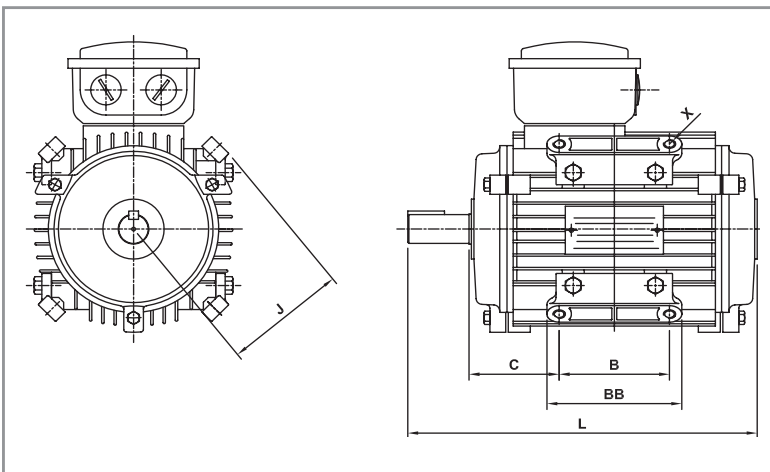

AIRSTREAM RATED PAD MOUNT B0

Motor frame	B	BB	C	J	L	X	
71	-14	71	89	55	82	205	M10
80	-19	90	110	55	97	237	M12
90S	-24	90	110	61	100	265	M12
90L	-24	90	110	73.5	100	290	M12
100L	-28	100	120	83	114	330	M12
112M	-28	100	120	90	125	340	M12
132S	-38	102	132	108	158	407	M16
132M	-38	140	170	108	158	445	M16
160M	-42						available on request
160L	-42						available on request

Pad mount motors are supplied by fitting 4 pads to the multi-mount motors. This option enables the mounting brackets to be fitted in a radial position relative to the motor shaft.

MODIFICATIONS AND VARIATIONS

TERMINAL BOX

Marathon® SLA motors come standard with a terminal box. Alternatively the terminal box can be replaced with a single conduit entry blanking plate and extended leads, including an earth.

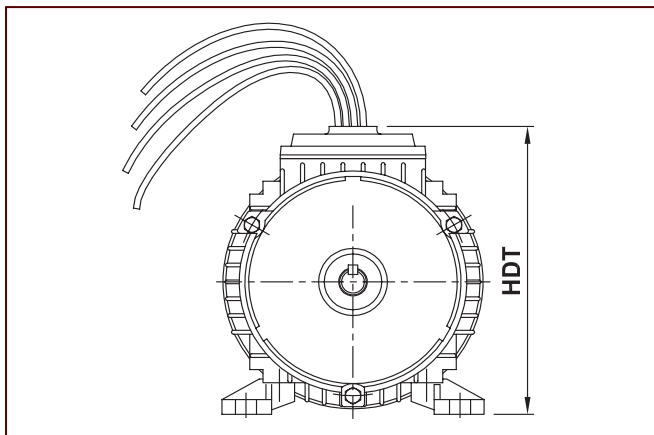

Motor frame	Conduit Size	HDT
56	On request	
63	M20 x 1.5	141
71	M20 x 1.5	156
80	M20 x 1.5	180
90S/L	M20 x 1.5	196
100L	M20 x 1.5	219
112M	M25 x 1.5	242
132S/M	M25 x 1.5	281
160M/L	available on request	

For either terminal box or blanking plate configuration feet can be relocated to provide wiring to the left or right side, or completely removed to enable mounting from the multi-mount pads.

BEARINGS

Regal Rexnord Australia can address applications where bearings need special consideration, including:

- Alternative bearing types
- Low/high temperature bearing grease

SHAFTS

Marathon® SLA motors come standard with a single output shaft to standard dimensions. The following alternatives are available:

- Double shaft extension
- Special shaft extension
- Stainless steel shaft material

ENDSHIELDS

Standard Marathon SLA endshields are all aluminium. For frames 90 to 160 they are fitted with steel inserts for the bearings. Cast iron or special endshields for customer applications can be manufactured to specification.

SLIDE RAILS

Regal Rexnord Australia stock slide rails to suit frame sizes from 80 to 160L. Rail sets are manufactured from cast iron and provided with mounting bolts and nuts between motor and rail.

ENVIRONMENTAL CONSIDERATIONS

Where environmental factors need special consideration Regal Rexnord can provide the following modifications:

- Winding temperature monitors and thermistors
- Anti-condensation heaters
- Separately powered cooling blowers
- Tropic proofing
- Special paint finish
- Higher IP ratings: IP56, IP65, and IP66
- High ambient temperature motors – SLAH with H class insulation

SPECIAL PERFORMANCE

Regal Rexnord is able to provide Marathon® SLA motors with special windings. These include:

- 10, 12 and 16 pole single speed windings
- Two, three and four speed windings
- Windings for alternative operating voltages and frequencies
- Windings designed for increased outputs and short time ratings



Industrial Solutions Regal Rexnord

HEAD OFFICE - AUSTRALIA

Regal Beloit Australia Pty Ltd ABN 61 122 303 084
19 Corporate Ave (PO Box 2340)
Rowville VIC 3178, Australia
Customer Service: 1300 888 853
T: +61 3 9237 4040
F: +61 3 9237 4050
salesAUvic@regalrexnord.com
www.regalaustralia.com.au

STATE OFFICES

VICTORIA

19 Corporate Avenue
Rowville VIC 3178
T: 1300 888 853
F: +61 3 9237 4050

NEW SOUTH WALES

8 Bushells Place
Wetherill Park NSW 2164
T: 1300 888 853
F: +61 2 8781 3131

QUEENSLAND

7 Mahogany Court
Willawong QLD 4110
T: 1300 888 853
F: +61 7 3246 3210

PRESENT IN

MACKAY

SOUTH AUSTRALIA

WESTERN AUSTRALIA

T: 1300 888 853

NEW ZEALAND

Regal Beloit New Zealand Limited
18 Jomac Place Avondale
Auckland, New Zealand
T: 0800 676 722
F: +64 9 820 8504

PRESENT IN

CHRISTCHURCH

ROTORUA

T: 0800 676 722

The proper selection and application of products and components, including assuring that the product is safe for its intended use, are the responsibility of the customer. To view our Application Considerations, please visit <https://www.regalrexnord.com/Application-Considerations>.

To view our Standard Terms and Conditions of Sale, please visit <https://www.regalrexnord.com/Terms-and-Conditions-of-Sale> (which may redirect to other website locations based on product family).

"Regal Rexnord" is not indicative of legal entity. Refer to product purchase documentation for the applicable legal entity.

Regal Rexnord and Marathon are trademarks of Regal Rexnord Corporation or one of its affiliated companies.

©2017, 2022 Regal Rexnord Corporation, All Rights Reserved.

MCC22035E • Form# SB0092E

