



MARATHON HGA SERIES CATALOGUE

ENHANCED PERFORMANCE CAST IRON MOTORS
SIZES 80 - 315, 0.75 - 160KW

REGAL[®]

HGA SERIES ENHANCED PERFORMANCE CAST IRON MOTORS

INTRODUCTION	3
Hazardous area certification, Efficiency & Standards and specifications	
Product code specification	4
MECHANICAL DESIGN	4
Mounting arrangements	4
PROTECTION	5
Materials and construction	5
TERMINAL BOX	6
Cooling	6
Bearings and Lubrication	7
Vibration, balancing and noise	8
ELECTRICAL DESIGN	8
Nameplate design	8
Alternative supplies	9
Temperature and altitude	9
Rotation	9
Duty	9-10
Connection	11
Starting	11
Insulation	12
Thermal protection	13
Speed at partial loads	13
Current at partial loads	13
Torque characteristics	13
INSTALLATION, OPERATION & MAINTENANCE	13
PERFORMANCE DATA	14 - 15
DIMENSIONAL DRAWINGS	16 - 18
SLIDE RAILS	18
AIRSTREAM RATED MOTORS FOR AXIAL FANS, HGAR	19
COOLING TOWER - HGAC	19
SMOKESPILL - HGAS/HGAHS	20
BRAKE MOTORS - HGAB	21
MOTORS FOR HAZARDOUS AREAS (IEC EX CERTIFIED)	22
Motor protection types	22
Hazardous area classifications	23-24
MODIFICATIONS, VARIATIONS AND OPTIONAL EXTRAS	24
Terminal box	24
Bearings	24
Shafts	25
Environmental considerations	25
Special performance	25
VVVF drives	25
TESTING SERVICES	25
MARINE APPROVAL	25

INTRODUCTION

This catalogue details the complete range of Regal Australia HGA series motors. Standard HGA motors are three phase squirrel cage TEFC (Totally Enclosed Fan Cooled), with IEC frame sizes from 80 to 315, with CENELEC frame allocation as standard. They combine excellent electrical characteristics with the robust strength of cast iron.

In addition to standard design, the range includes:

- HGAB** - Brake motors
- HGAE** - Hazardous location Ex e
- HGAN** - Hazardous location Ex nA
- HGAD** - Hazardous location Ex tD
- HGABD** - Hazardous location Ex tD, Brake motors
- HGAS** - Smokespill application
- HGAC** - Cooling tower application
- HGAR** - Airstream rated for Axial flow fans

All units are supplied with F Class insulation, with temperature rise being limited to less than 80K (unless otherwise marked). This provides the end user with a wide safety margin under general operating conditions.

In addition we also offer motors wound with H Class insulation, and temperature rise still limited to 80K.

- HGAH** - High ambient temperature application
- HGAHS** - H Class smokespill application

Additional protection is provided by installation of thermistors in all units from 160 frame upward to continuously protect the winding.

The conservative rating of Regal Australia type HGA motors provides additional operational safeguards, ensures long unit life, and renders this series inherently suitable for most arduous mining, industrial or agricultural applications.

HAZARDOUS AREA CERTIFICATION

HGA motors are certified for use in hazardous locations as per IECEx for Ex e, Ex nA and Ex tD protection. The certificate number is IECEx TSA 06.0034X issue No.4 and covers the following:

Motor frame	Protection	Location	Amb. Temp	Enclosure
80 - 280	Ex e II T3	Zone 1	40°C	IP55 (IP66 optional)
80 - 315	Ex nA II T3	Zone 2	50°C	IP55 (IP66 optional)
80 - 315	Ex tD A21 T135	Zone 21	50°C	IP66

The certificate also covers HGA 80 to 132 frame brake motors to Ex tD protection

EFFICIENCY

The HGA range of motors exceed MEPS2 requirements of AS/NZS1359.5:2004 with many sizes meeting High Efficiency levels of the same standard. HGA motors exceed European Eff1 levels and correspond to IE2 (High Efficiency) of the new international standard IEC 60034-30.

STANDARDS AND SPECIFICATIONS

The main dimensions and rated outputs of Regal Australia type HGA motors generally conform to International Standards IEC60034, IEC60072 and Australian Standard AS1359.

Product code specification

When placing an order the motor product code should be specified. The product code of the motor is composed in accordance with the following example:

M	3	2	0	0	1	5	0	3	H	G	A	E	/	4	0	5
1	2	3	4 - 8				9	10 - 12		13...		Suffix				

Position 1

M = metric frame size

Position 2

Winding design

3 = Standard three phase motors

Position 3

Number of poles

2 = 2 poles

4 = 4 poles

6 = 6 poles

8 = 8 poles

Positions 4 to 8

Rated power output

(kW x 100)

Position 9

Mounting arrangements

1 = V1

5 = B5

8 = B3/B14B

3 = B3

6 = B3/B14A

9 = B14B

4 = B3/B5

7 = B14A

Positions 10 to 12

Series

HGA = Regal Australia HGA series

Positions 13...*

Series variation

Blank = Standard

B = Brake motor

C = Cooling tower motors

D = Ex tD

E = Ex e

F = Flying leads

N = Ex n

H = Class H insulation

L = Left hand terminal box

M = Mining Spec

R = Airstream rated

S = Smokespill

T = Top terminal box

* Multiple letters indicate multiple variation.

Suffix

Winding design

Blank = 380 - 415V / 50Hz, 440 - 480V / 60Hz

/A05 = 1000V / 50Hz

/386 = 380V / 60Hz

/B05 = 1100V / 50Hz

/525 = 525V / 50Hz

MECHANICAL DESIGN

MOUNTINGS

Marathon® HGA motors are available in the mounting arrangements listed in the table below:

<p>B3 (IM1001) [63 - 450]</p>	<p>B6 (IM1051) [63 - 160]</p>	<p>B7 (IM1061) [63 - 160]</p>
<p>B3 (IM1001) [63 - 450]</p>	<p>V5 (IM1011) [63 - 160]</p>	<p>V6 (IM1031) [63 - 160]</p>
<p>B8 (IM1071) [63 - 160]</p>	<p>V1 (IM3011) [63 - 450]</p>	<p>V3 (IM3031) [63 - 160]</p>
<p>B5 (IM3001) [63 - 280]</p>	<p>V15 (IM2011) [63 - 160]</p>	<p>V35 (IM2031) [63 - 160]</p>
<p>B35 (IM2001) [63 - 450]</p>	<p>V18 (IM3611) [63 - 132]</p>	<p>V19 (IM3631) [63 - 132]</p>
<p>B14 (IM3601) [63 - 132]</p>	<p>V17 (IM2111) [63 - 132]</p>	<p>V37 (IM2131) [63 - 132]</p>

PROTECTION

FOR VERTICALLY MOUNTED MOTORS

Motors to be mounted with the shaft vertically down must be provided with a suitable cover (available on request) to ensure foreign bodies are prevented from entering the motor.

Special care is necessary in fitting protective covers to ensure air flow is not impeded (refer to Cooling section on page 6).

To maintain IP rating, special additional measures may be required to protect the motor against the ingress of water or foreign bodies. Please contact Regal for further information.

AGAINST SOLAR RADIATION

High solar radiation will result in undue temperature rise. In these circumstances motors should be screened from solar radiation by placement of adequate sunshades which do not inhibit air flow.

DEGREE OF PROTECTION

Standard levels of enclosure protection for all HGA frame sizes for both motor and terminal box is IP55, with IP56, IP65 and IP66 available on request.

Enclosure designations comply with IEC or AS60529. The enclosure protection required will depend upon the environmental and operational conditions within which the motor is to operate.

IP STANDARDS EXPLANATION

IP	5	5
1-2	3	4

POSITIONS 1 AND 2

International protection rating prefix

POSITION 3

First characteristic numeral

Degree of protection of persons against approach to live parts or contact with live or moving parts (other than smooth rotating shafts and the like) inside the enclosure, and degree of protection of equipment within the enclosure against the ingress of solid foreign bodies.

4 = *Protected against solid object greater than 1.0 mm:*
Wires or strips of thickness greater than 1.0 mm, solid objects exceeding 1.0 mm

5 = *Dust protected:* Ingress of dust is not totally prevented but it does not enter in sufficient quantity to interfere with satisfactory operation of the equipment.

6 = *Dust tight:* No ingress of dust.

POSITION 4

Second characteristic numeral

4 = *Protected against splashing water:* Water splashed against the enclosure from any direction shall have no harmful effect.

5 = *Protected against water jets:* Water projected by a nozzle against the enclosure from any direction shall have no harmful effect.

6 = *Protected against heavy seas:* Water from heavy seas or water projected in powerful jets (larger nozzle and higher pressure than second numeral 5) shall not enter the enclosure in harmful quantities

MATERIALS AND CONSTRUCTION

Element	Motor frame size	
	80-180	200-315
Frame	Cast iron	Cast iron
Endshields	Cast iron	Cast iron
Terminal box	Cast iron	Cast iron
Fan	Plastic (cast iron optional)	Plastic (cast iron optional)
Fan cowl	Sheet steel	Sheet steel
Fasteners	Corrosion protected	Corrosion protected

SHAFT

HGA motors have standard shaft extension lengths and are provided with standard key, and drilled and tapped hole. Non standard shaft extensions are available upon special order, with shaft design outlined on a detailed drawing.

Shaft extension run out, concentricity and perpendicularity to face of standard flange mount motors, comply with normal grade tolerance as specified in IEC 60072-1 and AS1359. Precision grade tolerance is available upon special order.

FINISH

Standard HGA motor color is RAL 7030 Stone Grey. Other colors are also available. All castings and steel parts are provided with a prime coat of rust-resistant paint.

The finishing coat of enamel paint is sufficient for normal conditions, however special paint systems can be provided to accommodate stringent requirements for motors in corrosive environments. Special coatings are needed to resist such substances as acid, salt water and extreme climatic conditions.

Different colors and paint systems apply for varieties as described later in this catalogue.

TERMINAL BOX

HGA motors have a cast iron terminal box with a one piece nitrile rubber barrier gasket between terminal box and motor, and a flat gasket under the terminal box lid. The earthing arrangement is available within the terminal box.

As standard the terminal box is mounted on the right hand side when viewed from drive end. Motors are also available with terminal boxes on the left hand side or top.

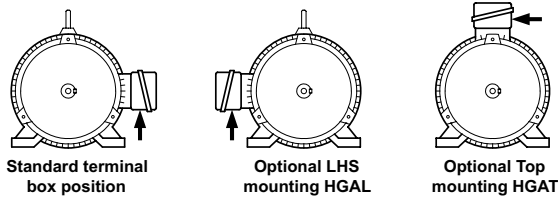

→ indicates conduit entry position

Conduit entries for motor frame sizes 80 to 280 are provided tapped, with thread details set out below. Motor frame size 315 is provided with a blank removable gland plate for machining as required.

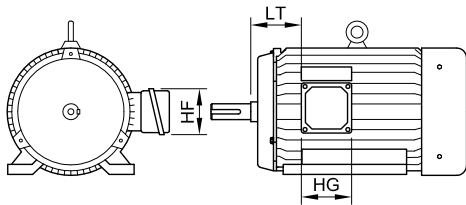

Motor frame	Dimensions			Entry/pitch Standard	Number of entries
	HE	HF	LTE		
80 ²⁾	127	135	40	M20 x 1.5	2
90S ²⁾	127	135	45	M20 x 1.5	2
90L ²⁾	127	135	60	M20 x 1.5	2
100L	135	127	75	M20 x 1.5	2
112M	135	127	80	M25 x 1.5	2
132S	135	127	100	M25 x 1.5	2
132M	135	127	120	M25 x 1.5	2
160M	200	175	65	M32 x 1.5	2
160L	200	175	90	M32 x 1.5	2
180M	200	175	65	M40 x 1.5	2
180L	200	175	65	M40 x 1.5	2
200	240	195	55	M50 x 1.5	2
225	240	195	90	M50 x 1.5	2
250	270	235	95	M50 x 1.5	2
280	270	235	90	M50 x 1.5	2
315	355	300	90	10 mm Gland plate	Nil/2

¹⁾ Dimension LT should be confirmed for HGAL motors.

²⁾ Conduit entry faces to rear of motor for frames 80 & 90.

For details of motors fitted with extended leads please refer to page 22.

The terminal box can be rotated through 4 positions, 90° apart. Terminal boxes are fitted with conduit entries arranged as follows:

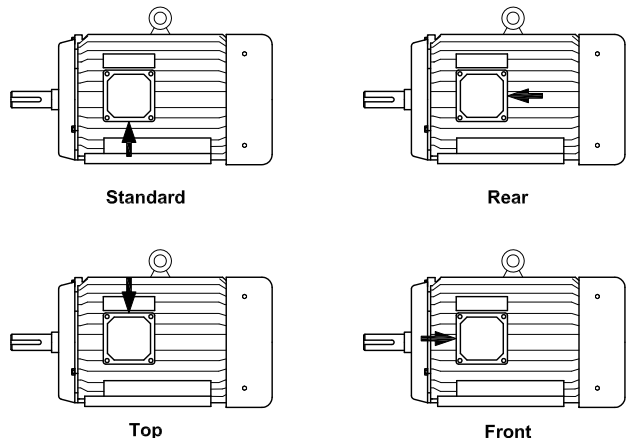

HGA - Standard²⁾

HGAR - Rear

HGAT - From RHS when viewed from drive end

²⁾ Conduit entry faces to rear of motor for frames 80 & 90.

COOLING

HGA motors are totally enclosed fan cooled (TEFC) over an externally ribbed frame, with free movement of internal air by rotation of rotor blades, which is in accordance with IC0141 of IEC 60034-6 and AS1359.106.

Cooling air flows from the non-drive-end to the drive end. The fan is independent of the direction of rotation of the motor.

When the motor is installed care should be taken not to impede the air flow into the motor cowl. As a guide the following minimum dimension BL should be adopted.

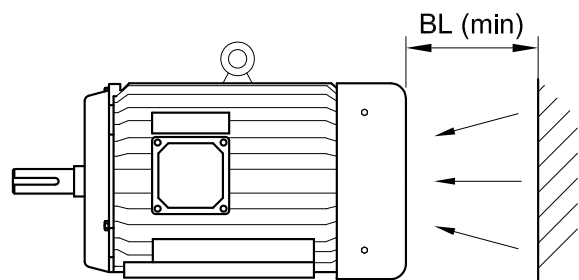

Motor frame	Dimension BL [mm]
80-100	15
112-132	30
160-180	40
200-280	50
315	65

BEARINGS

As standard, frame sizes 80 to 180 have high quality deep groove sealed ball bearings. Bearings are prepacked with grease which, under normal operating conditions, provide a high degree of operational reliability. Frame sizes 200 to 315 have high quality bearings with facilities to enable replenishment of the lubricant during operation. Grease nipples are fitted to endshields with the grease relief chute blanked off by a removable plate.

The table below sets out the permissible forces that can be applied to the motor shaft. Values assume the occurrence of only radial or axial loading. Point of application of the force is assumed to be at the tip of the shaft. Rotor weights have already been allowed for in the calculation of radial and axial loads. These loads are applicable for horizontal mounting only. The values are calculated on the basis of basic rating life or fatigue life L_{10} of 40,000 hours. Adjusted rating life for specific applications can be calculated if all influencing factors are known.

Greater axial forces can be tolerated if the motors are provided with angular contact ball bearings. Note that in such cases, the axial force must operate in one direction.

Bearing arrangement should be reviewed for motor frame sizes 200 and above if they are vertically mounted. Please contact Regal for further information.

HIGH CAPACITY BEARINGS

For frame sizes 200 to 280 in applications with increased radial force, cylindrical roller bearings can be substituted for ball bearings at the drive end, according to the accompanying table. When a roller bearing is fitted to the D-end, the N-end ball bearing is locked with a circlip to prevent axial movement. Note that the use of roller bearings is not recommended for 2 pole motors.

PERMISSIBLE RADIAL FORCE - HIGH CAPACITY

Motor frame	D-end Rolle	N-end Rolle	Permissible radial force [N]		
			4 Pole	6 Pole	8 Pole
200	NU312	6312	5825	6730	7455
225	NU313	6313	6015	7055	7740
250	NU314	6314	7295	8420	9315
280	NU317	6317	13445	15320	16770

LUBRICATION

HGA motors standard bearings are lubricated with lithium based rolling contact bearing grease suitable for operation within the cooling air temperature range of -20°C to +55°C. For operation outside this temperature range special lubricants are required. HGAH, HGAS and HGAHS motors use Magnalube G grease.

Special lubricants or additional maintenance may be required in the case of motors exposed to comparatively high degrees of pollution, high humidity, increased or changed bearings loads, or prolonged continuous operation.

PERMISSIBLE RADIAL AND AXIAL FORCES – STANDARD B3 MOUNTED MOTORS

Motor frame	Bearing		Permissible radial force [N]				Permissible axial force [N]			
	D-end	N-end	2 pole	4 pole	6 pole	8 pole	2 pole	4 pole	6 pole	8 pole
80	6204-2Z	6204-2Z	465	595	685	-	395	540	650	-
90	6205-2Z	6205-2Z	490	620	720	-	415	570	685	-
100	6206-2Z	6206-2Z	700	885	1030	1140	570	775	940	1075
112	6306-2Z	6306-2Z	960	1230	1415	1575	785	1080	1305	1515
132	6308-2Z	6308-2Z	1410	1815	2095	2320	1160	1590	1910	2200
160	6309-2Z	6309-2Z	1825	2345	2710	3020	1470	2030	2450	2800
180	6311-2Z	6311-2Z	2495	3200	3765	4200	1985	2700	3265	3755
200	6312	6312	2905	3745	4345	4825	2220	3055	3705	4225
225	6313	6313	3265	4010	4725	5205	2460	3385	4120	4730
250	6314	6314	3570	4635	5370	5960	2730	3775	4560	5220
280-2	6314	6314	3455				2605			
280-4,6,8	6317	6317		8170	9360	10270		4560	5580	6365
315-2	6316	6316	3550				2730			
315-4,6,8	NU319	6319		15720	17925	19660		4835	5890	6770

VIBRATION

HGA motors fall within the Level N (normal) limits of vibration severity set out in standards IEC 60034-14:1996 and AS1359.114 (which are listed in the table below). As specified in the standards, these values relate to rotating machinery measured in soft suspension.

VIBRATION SEVERITY LIMIT, LEVEL N

Motor frame	Maximum RMS vibration velocity [mm/s]
80	1.8
90	1.8
100	1.8
112	1.8
132	1.8
160	2.8
180	2.8
200	2.8
225	2.8
250	3.5
280	3.5
315	3.5

BALANCING

Rotors have been dynamically balanced with a half key. Pulleys or couplings used with motors must also be appropriately balanced.

NOISE

Noise levels for HGA motors comply with limits set by IEC 60034.9 and AS1359.109. HGA sound pressure levels at 1 metre are set out in the table (above right). Data relates to motors tested at no load.

SOUND PRESSURE LEVEL

Output [kW]	Sound pressure level dB(A) at 1m.			
	2 Pole	4 Pole	6 Pole	8 Pole
0.75	65	61	59	56
1.1	65	61	60	56
1.5	69	61	60	56
2.2	69	63	60	56
3.0	72	63	64	59
4.0	72	67	64	59
5.5	76	68	68	65
7.5	76	71	68	65
11	80	72	70	65
15	80	74	70	67
18.5	80	74	70	67
22	85	74	70	68
30	87	76	73	70
37	87	76	73	70
45	89	76	76	70
55	89	78	76	74
75	91	81	78	76
90	91	81	78	76
110	92	84	79	76
132	92	86	80	
160	92	87		

ELECTRICAL DESIGN

As standard, HGA motors have the following design and operating parameters. Performance data is based on this standard. Any deviation should be examined and performance values altered in accordance with the information provided in this section.

Three phase, 380 - 415V/ 50Hz, 440 - 480V/ 60Hz
 Ambient cooling air temperature, 40°C
 Altitude 1000m
 Duty cycle S1 (continuous)
 Rotation Clockwise viewed from drive end
 Connection 230V Delta/400V Star (3kW and below)
 400V Delta/690V Star (4kW and above)

NAMEPLATE DESIGN

Standard HGA motors are suitable to operate at 380-415V 50Hz and 440-480V 60Hz supplies. This is indicated on the standard nameplate design as shown below.

Motors 3kW and below:

CMG AUSTRALIA		THREE PHASE ASYNCHRONOUS MOTOR				CE IEC 60034	
		TYPE HGA100LB-4					
DUTY	S1	INS. CL.	F	IP	55	EFF1	
VOLTS	CONN.	Hz	kW	RPM	AMPS	COSφ	EFF %
220 - 240	DELTA	50	3.0	1460	11.0	0.79	87.8
380 - 415	STAR	50	3.0	1460	6.3	0.79	87.8
440 - 480	STAR	60	3.5	1750	6.3		
6206 - C3				6206 - C3			
PROD No.		M34003003HGA			AMB. TEMP. 40 °C		
SERIAL No.		xxxxxxx			F 10	Wt. 40 kg	

Motors 4kW and above:

CMG AUSTRALIA		THREE PHASE ASYNCHRONOUS MOTOR				CE IEC 60034	
		TYPE HGA112M-4					
DUTY	S1	INS. CL.	F	IP	55	EFF1	
VOLTS	CONN.	Hz	kW	RPM	AMPS	COSφ	EFF %
380 - 415	DELTA	50	4.0	1450	8.1	0.80	88.3
660 - 720	STAR	50	4.0	1450	4.7	0.80	88.3
440 - 480	DELTA	60	4.6	1740	8.1		
6306 - C3				6306 - C3			
PROD No.		M34004003HGA			AMB. TEMP. 40 °C		
SERIAL No.		xxxxxxx			F 10	Wt. 54 kg	

Nameplate currents correspond to the mid-point of the supply range (230/400/690V 50Hz and 460V 60Hz). Currents and torques at other supplies in reference to standard 400V 50Hz supply are shown in table on next page.

NOTICE: This table is not applicable for hazardous area motors

Supply	Data in percentage of values at 400V/50Hz supply						
	Output	r/min	I _N	I _L /I _N	T _N	T _L /T _N	T _B /T _N
380V 50Hz	100	100	105	91	100	90	90
415V 50Hz	100	100	96	108	100	108	108
400V 60Hz	100	120	98	83	83	70	85
415V 60Hz	104	120	98	89	86	75	88
440V 60Hz	110	120	98	95	91	85	93
460V 60Hz	115	120	100	100	96	93	98
480V 60Hz	120	120	100	105	100	100	103

- 1) I_N = Full load current
 I_L/I_N = Locked rotor current/ full load current
 T_B/T_N = Breakdown torque/full load torque
 T_N = Full load torque
 T_L/T_N = Locked rotor torque/ full load torque

ALTERNATIVE SUPPLIES

HGA motors can be manufactured for any voltage between 100V and 1100V and frequencies other than 50Hz. In case motor winding is designed for a specific voltage x, performance data will be in line with standard 400V data except current which is calculated with the following formula:

$$I_x = \frac{400 \times I_N}{U_x}$$

Where:

- I_x = Current
 I_N = Full load current at 400 volt
 U_x = Design voltage

TEMPERATURE AND ALTITUDE

Rated power specified in the performance data tables apply for standard ambient conditions of 40°C at 1000m above sea level. Where temperature or altitude differ from the standard, multiplication factors in the table below should be used.

Ambient temperature	Temp. factor	Altitude above sea level	Altitude factor
30°C	1.06	1000m	1.00
35°C	1.03	1500m	0.98
40°C	1.00	2000m	0.94
45°C	0.97	2500m	0.91
50°C	0.93	3000m	0.87
55°C	0.88	3500m	0.82
60°C	0.82	4000m	0.77

$$\text{Effective Power} = \text{Rated Power} \times \text{Temperature Factor} \times \text{Altitude Factor}$$

Example 1

Effective Power required = 15kW
 Air temperature = 50°C (factor 0.93)
 Altitude = 2500 metres (factor 0.91)

$$\text{Rated power required} = \frac{15}{0.93 \times 0.91} = 17.7\text{kW}$$

The appropriate motor is one with a rated power above the required, being 18.5kW.

Example 2

Rated power = 11kW
 Air temperature = 50°C (factor 0.93)
 Altitude = 1500 metres (factor 0.98)

$$\text{Effective Power} = \frac{11 \times 0.93}{0.98} = 10.0\text{kW}$$

ROTATION

For clockwise rotation, viewed from drive end, standard three phase HGA and HGAT motor terminal markings coincide with the sequence of the phase line conductors.

For counter clockwise rotation, viewed from drive end, two of the line conductors have to be reversed. This is made clear in the accompanying table.

Terminal box location (viewed from drive end)	Sequential connection of L1, L2 and L3	Direction of rotation
Right or Top	U1 V1 W1 V1 U1 W1	Clockwise Counter-clockwise
Left	V1 U1 W1 U1 V1 W1	Clockwise Counter-clockwise

Non-standard HGAL series motors with the terminal box located on the left, viewed from drive end, have a counter-clockwise rotation for corresponding markings. Reversing two of the line conductors will reverse the rotation to clockwise.

DUTY

HGA motors are supplied suitable for S1 operation (continuous operation under rated load). When the motor is to operate under any other type of duty the following information should be supplied to determine the correct motor size:

- Type and frequency of switching cycles as per duty factors S3 to S7 and duty cycle factor.
- Load torque variation during motor acceleration and braking (in graphical form).
- Moment of inertia of the load on the motor shaft.
- Type of braking (eg mechanical, electrical through phase reversal or DC injection).

PERMISSIBLE OUTPUT

Apply the factors in the accompanying table to the output rating for motors with duty cycles that are not continuous.

	Poles	Duty cycle factor		
		For frames 80 to 132	For frames 160 to 250	For frames 280 to 315
Short-time duty, S2				
30 min	2	1.05	1.20	1.20
	4 to 8	1.10	1.20	1.20
60 min	2 to 8	1.00	1.10	1.10
Intermittent duty, S3				
15%	2	1.15	1.45	1.40
	4 to 8	1.40	1.40	1.40
25%	2	1.10	1.30	1.30
	4 to 8	1.30	1.25	1.30
40%	2	1.10	1.10	1.20
	4 to 8	1.20	1.08	1.20
60%	2	1.05	1.07	1.10
	4 to 8	1.10	1.05	1.10

For other duties (S4, S5, S6 and S7) contact Regal Australia for appropriate duty cycle factors.

DUTY CYCLES

S1 Continuous duty

Operation at constant load of sufficient duration for thermal equilibrium to be reached.

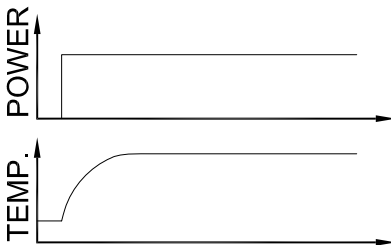

S2 Short - time duty

Operation at constant load during a given time, less than that required to reach thermal equilibrium, followed by a rest (de-energised) period of sufficient duration to allow machine temperatures to reduce to within 2K of the rated inlet coolant temperature.

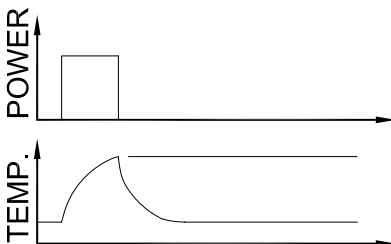

S3 Intermittent periodic duty with insignificant starting time

A sequence of identical duty cycles where each consists of a period of operating at constant load and a period at rest. The cycle is such that the starting current does not significantly affect the temperature rise.

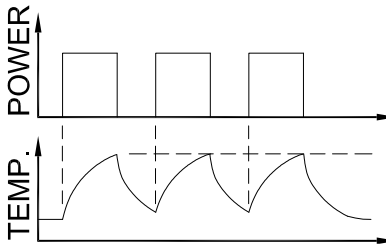

S4 Intermittent periodic duty with significant starting time

Sequence of identical duty cycles where each cycle consists of a significant period of starting, a period of operation at full load and a period of rest.

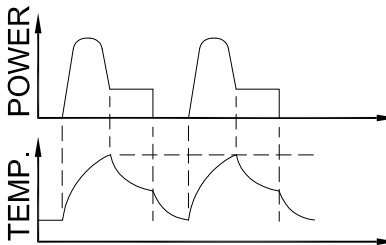

S5 Intermittent periodic duty with influence of running up period and electric braking

As S4, but with each cycle including a period of rapid electric braking.

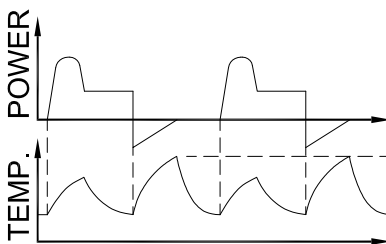

S6 Continuous periodic duty

A sequence of identical duty cycles, each cycle consisting of a period of operation at no-load. There is no rest or de-energised period.

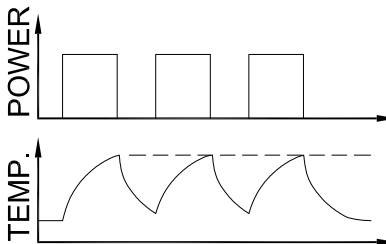

S7 Continuous periodic duty with starting and electric braking

As S6, with each cycle including a period of starting and a period of electric braking.

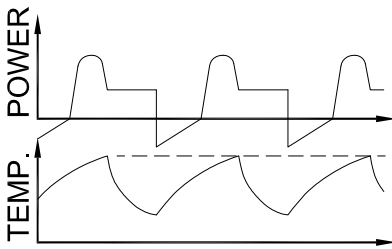

CONNECTION

A motor's rated voltage must agree with the power supply line-to-line voltage. Care must therefore be taken to ensure the correct connection to the motor terminals

INTERNAL CONNECTIONS, VOLTAGES AND VF DRIVE SELECTION

Standard terminal connections for motors 3.0kW and below is 230V delta / 400V star. These motors are designed for 400V Direct On Line (D.O.L.) starting, when connected in the star configuration. They are also suitable for operation with 230V three phase variable frequency drives, when connected in the delta configuration.

Standard terminal connections for motors 4.0kW and above is 400V delta / 690V star. These motors are designed for 400V D.O.L. starting, when connected in the delta configuration. They are also suitable for operation with 400V three phase variable frequency drives. Alternatively, they can be operated D.O.L. in the star configuration from a 690V supply or with a 690V variable frequency drive. In this case the drive must be supplied with an output sine wave filter to protect the winding insulation. These size motors are also suitable for 400V star-delta starting as described below.

Motor connected for D.O.L. starting with bridges in place for star connection (3.0kW and below)

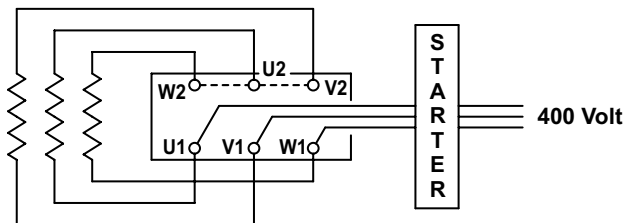

Motor connected for D.O.L. starting with bridges in place for delta connection (4.0kW and above).

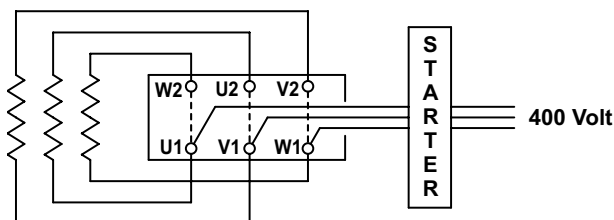

STARTING

All of the following starter options are available through Regal Australia Drives division, and are best supplied together with the motor.

D.O.L. STARTERS

When an electric motor is started by direct connection to the power supply (D.O.L.), it draws a high current, called the 'starting current', which is approximately equal in magnitude to the locked rotor current I_L . As listed in the performance data, locked rotor current can be up to 8 times the rated current I_N of the motor. In circumstances where the motor starts under no load or where high starting torque is not required, it is preferable to reduce the starting current by one of the following means.

STAR - DELTA STARTING

HGA motors 4.0kW and above are suitable for the star-delta starting method. Through the use of a star-delta starter, the motor terminals are connected in the star configuration during starting, and reconnected to the delta configuration when running.

The benefits of this starting method are a significantly lower starting current, to a value about 1/3 of the D.O.L. starting current, and a corresponding starting torque also reduced to about 1/3 of its D.O.L. value. It should be noted that a second current surge occurs on changeover to the delta connection. The level of this surge will depend on the speed the motor has reached at the moment of changeover.

ELECTRONIC SOFT STARTERS

Through the use of an electronic soft starter, which controls such parameters as current and voltage, the starting sequence can be totally controlled. The starter can be programmed to limit the amount of starting current. By limiting the rate of the current increase the startup time is extended. This starting method is particularly suitable for centrifugal loads (fans and pumps).

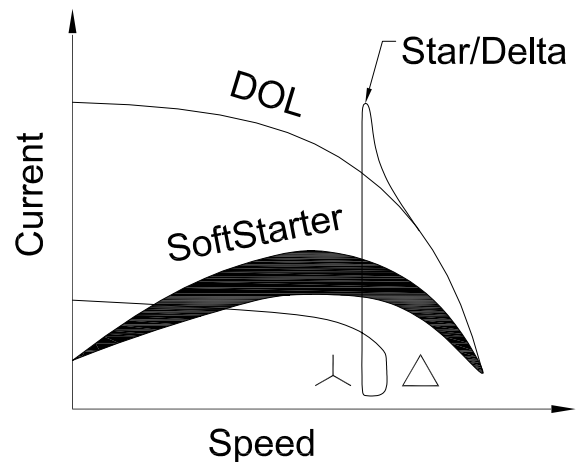

VVVF DRIVES

The HGA motor performs excellently without cogging at low speed when operating in conjunction with a VVVF (Variable Voltage Variable Frequency) drive. VVVF drives are primarily recognized for their ability to manipulate power from a constant 3 phase 50/60Hz supply converting it to variable voltage and variable frequency power. This enables the speed of the motor to be matched to its load in a flexible and energy efficient manner. The only way of producing starting torque equal to full load torque with full load current is by using VVVF drives. The functionally flexible VVVF drive is also commonly used to reduce energy consumption on fans, pumps and compressors and offers a simple and repeatable method of changing speeds or flow rates.

For operation below 25Hz motor cooling fan efficiency drops significantly. Hence, in constant torque applications, a separately driven cooling fan should be fitted to provide sufficient cooling of the motor.

For operation between 25Hz and 50Hz speed range the motor is capable of delivering full rated torque with its standard fan.

For operation above 50Hz, all HGA motors are capable of delivering constant rated power up to 60Hz. However, most of these motors are suitable to run and deliver constant power at much higher frequencies than 60Hz to a maximum of 100Hz. In the case of applications between 60Hz and 100Hz please contact Regal Australia for advice on suitability.

The HGA range of motors will operate without modification on VVVF drives however under certain conditions additional features should be considered (see EDM Concerns). The graph below shows the HGA motors' loadability with a frequency converter:

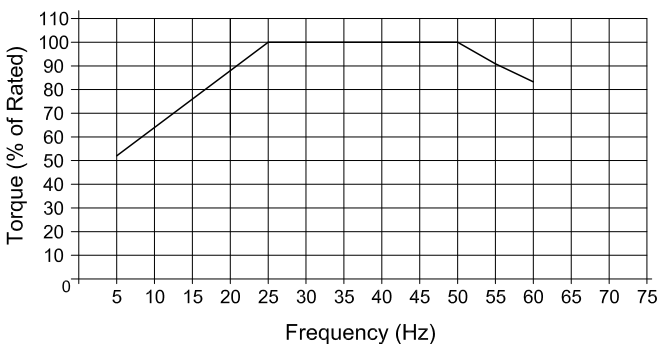

EDM CONCERNS

Capacitive voltages in the rotor can be generated due to an effect caused by harmonics in the waveform causing voltage discharge to earth through the bearings. This discharge results in etching of the bearing running surfaces. This effect is known as Electrical Discharge Machining (EDM). It can be controlled with the fitment of appropriate filters to the drive.

To further reduce the effect of EDM, an insulated non drive bearing can be used. Regal Australia recommends the use of insulated bearings for all motors 315 frame.

INSULATION

Standard HGA series motors are wound with F class insulation and winding designs limit the temperature rise to 80K (unless otherwise noted) for which B Class insulation would normally be sufficient. The use of F class insulation provides an additional safety margin of 25K, as shown in the accompanying table, together with an extended operating life.

	Insulation class		
	B	F	H
Max. permissible winding temp. (°C)	130	155	180
Less ambient temp. (°C)	-40	-40	-40
Less hotspot allowance (K)	-10	-10	-15
Equals max. permissible temp.rise (K)	80	105	125
Less max. design temperature rise (K)	-80	-80	-80
Equals min. safety margin (K)	-	25	45

The HGAH version will provide a safety margin of 45K and can be safely operated at elevated ambient temperatures.

Due to their conservative design many sizes in the HGA range of motors have temperature rises considerably less than 80K and therefore provide even greater safety margins.

THERMAL PROTECTION

Motors can be protected against excessive temperature rise by inserting, at various positions within the windings, thermal probes which can either give a warning signal or cut off the supply to the motor in the event of a temperature abnormality.

The units fitted to HGA motors, frame sizes 160 and above, are PTC thermistors. These thermovaryable resistors, with positive temperature co-efficient, are fitted one per phase, series connected and are terminated in a terminal strip located in the terminal box. Trip temperature is 160°C (180°C for HGAH series). Additional 130°C thermistors can be fitted as an option for alarm connection.

SPEED AT PARTIAL LOADS

The relationship between motor speed and degree of loading on an HGA motor is approximately linear up to the rated load. This is expressed graphically in the accompanying drawing.

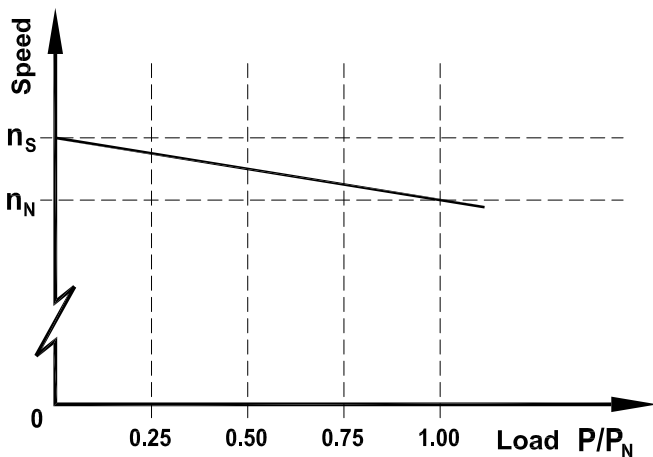

Where:

- n_N = full load speed
- n_s = synchronous speed
- P/P_N = partial load factor

CURRENT AT PARTIAL LOADS

Current at partial loads can be calculated using the following formula:

$$I_x = \frac{P_{out_x}}{\sqrt{3} \times U_N \times \cos \phi_x \times \eta_x} \times 10^5$$

Where:

- I_x = partial load current (amps)
- P_{out_x} = partial load (kW)
- U_N = rated voltage
- $\cos \phi_x$ = partial load power factor
- η_x = partial load efficiency (%)

TORQUE CHARACTERISTICS

Typical characteristics of torque behaviour relative to speed are shown in the torque speed curve example below.

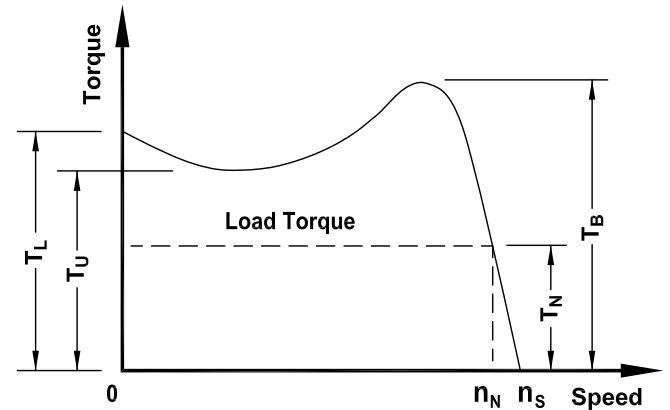

Where:

- T_N = full load torque
- T_L = locked rotor torque
- T_U = pull-up torque
- T_B = break down torque
- n_N = full load speed
- n_s = synchronous speed

HGA motors all exceed the minimum starting torque requirements for Design N (Normal torque) as specified in IEC60034-12, and in most cases meet the requirements of Design H (High torque).

Rated torque can be calculated with the following formula:

$$T_N = \frac{9550 \times P_N}{n_N}$$

Where:

- T_N = full load torque (Nm)
- P_N = full load output power (kW)
- n_N = full load speed (r/min)

INSTALLATION, OPERATION & MAINTENANCE

For a copy of the Installation, Operation & Maintenance manual, please contact Regal or download from our website at www.regalaustralia.com

PERFORMANCE DATA

HGA SERIES, THREE PHASE, 380-415V 50HZ IP55, F CLASS INSULATION, B CLASS TEMPERATURE RISE

kW	Motor frame	Speed [r/min]	400V 50Hz									t _E timeĒ [sec]	380V 50Hz	415V 50Hz	Moment of Inertia J=¼GD ² (kgm ²)	Weight of foot mount motor (kg)
			Efficiency at % full load		Power factor at % full load		Current		Torque				Current	Current		
			100%	75%	100%	75%	Full load I _N [A]	Locked rotor I _L /I _N	Full load T _N [Nm]	Locked rotor T _L /T _N	Break down T _B /T _N		Full load I _N [A]	Full load I _N [A]		
3000 R/MIN = 2 POLES																
0.75*	80A	2870	82.4	83.2	0.85	0.79	1.55	7.2	2.5	2.9	3.1	11	1.61	1.52	0.001	18
1.1	80B	2890	83.4	83.5	0.85	0.80	2.2	8.0	3.6	3.2	3.2	12	2.3	2.2	0.001	18.5
1.5*	90S	2910	86.3	85.7	0.84	0.77	3.0	9.7	4.9	4.1	4.4	6	3.0	2.9	0.001	24
2.2*	90L	2900	87.5	87.4	0.85	0.80	4.2	9.5	7.2	3.9	3.8	5	4.4	4.2	0.002	26
3*	100L	2900	88.1	88.5	0.88	0.85	5.6	8.5	9.9	3.0	3.5	6	5.8	5.4	0.004	37
4	112M	2915	88.8	88.9	0.89	0.85	7.3	9.4	13.1	3.0	4.0	9	7.6	7.2	0.006	48
5.5	132SA	2925	89.1	88.8	0.89	0.86	10.1	7.7	18.0	2.3	3.3	7	10.4	9.8	0.013	62
7.5	132SB	2920	90.2	90.4	0.90	0.88	13.4	7.9	24.5	2.3	3.0	12	14.0	13.0	0.015	73
11*	160MA	2950	92.3	91.8	0.88	0.85	19.6	7.9	35.6	2.3	3.0	6	20.3	19.1	0.045	121
15*	160MB	2950	92.5	92.3	0.89	0.86	26.4	7.8	48.6	2.1	2.9	6	27.4	25.9	0.051	129
18.5	160L	2940	92.3	92.3	0.89	0.87	32.5	7.6	60.1	2.1	2.7	5	34.0	31.7	0.057	151
22	180M	2950	93.1	93.0	0.88	0.86	38.6	7.9	71.2	2.4	2.7	5	40.1	37.7	0.078	184
30*	200LA	2970	94.2	93.6	0.87	0.83	53.0	9.1	96.5	3.0	2.9	5	55	52	0.141	260
37	200LB	2960	93.3	92.8	0.88	0.85	65.0	6.5	119.4	2.4	2.6	5	68	62	0.158	268
45	225M	2975	93.9	93.7	0.88	0.86	79.0	9.1	144.5	2.3	2.5	7	81	76	0.241	332
55	250M	2970	94.6	94.0	0.90	0.89	93.0	8.9	176.9	2.5	2.8	5	98	91	0.331	405
75	280S	2975	94.9	94.3	0.91	0.89	126.0	9.4	240.8	3.2	3.5	14	131	123	0.605	550
90	280M	2980	95.4	95.1	0.92	0.92	147.0	7.1	288.4	2.2	2.7	5	156	143	0.685	620
110*	315S	2985	96.0	95.6	0.92	0.91	180.0	6.0	351.9	2.0	2.5	-	190	174	1.185	980
132*	315M	2983	95.5	94.9	0.90	0.90	222.0	6.0	423.0	2.1	2.3	-	230	212	1.87	1080
160*	315LA	2985	96.8	96.7	0.92	0.92	260.0	5.4	511.9	2.0	2.4	-	273	249	2.15	1160
1500 R/MIN = 4 POLES																
0.75	80B	1430	82.3	82.2	0.74	0.68	1.79	6.0	5.0	2.7	3.1	50	1.8	1.77	0.002	22
1.1	90S	1425	84.2	84.8	0.74	0.67	2.55	6.2	7.4	2.9	3.0	35	2.6	2.5	0.003	23.5
1.5*	90L	1430	86.5	87.0	0.75	0.68	3.3	7.0	10.0	3.2	3.4	21	3.4	3.3	0.003	28.5
2.2	100LA	1455	86.7	86.2	0.78	0.71	4.7	8.3	14.4	3.1	3.5	22	4.8	4.7	0.006	38
3	100LB	1460	87.8	87.6	0.79	0.73	6.3	8.0	19.6	2.9	3.8	16	6.3	6.3	0.007	40
4	112M	1450	88.3	88.5	0.80	0.75	8.1	7.4	26.3	2.6	3.4	20	8.3	8.1	0.011	54
5.5*	132S	1460	90.4	90.9	0.83	0.80	10.6	7.6	36.0	2.0	2.7	20	11.0	10.4	0.023	71
7.5	132M	1455	90.6	91.2	0.84	0.80	14.3	7.4	49.2	2.3	2.8	15	14.8	14.0	0.032	84
11	160M	1470	91.2	91.0	0.84	0.80	20.7	7.4	71.5	2.1	3.2	9	21.2	20.7	0.079	127
15	160L	1470	92.0	92.0	0.86	0.82	27.3	7.5	97.4	2.0	3.2	8	28.3	27.2	0.096	148
18.5	180M	1470	92.2	92.2	0.88	0.84	33.1	7.5	120.2	2.1	3.2	17	34.3	32.5	0.146	186
22	180L	1470	93.0	93.2	0.90	0.89	38	7.9	142.9	2.0	3.0	8	39.8	36.9	0.168	194
30	200L	1475	94.0	93.8	0.86	0.83	53	8.7	194.2	2.3	2.5	7	55	53	0.268	260
37*	225S	1485	94.7	94.8	0.88	0.87	64	7.1	238.0	2.0	2.4	9	67	62	0.415	310
45	225M	1485	94.6	94.4	0.87	0.84	79	8.9	289.4	2.0	2.5	7	81	79	0.475	388
55	250M	1480	94.4	94.1	0.89	0.87	95	9.1	354.9	2.4	2.6	6	99	91	0.67	430
75	280S	1485	94.8	94.7	0.88	0.86	129	6.3	482.3	2.1	2.5	7	136	126	1.13	662
90*	280M	1480	95.9	96.2	0.90	0.89	151	6.6	580.7	2.2	2.5	7	160	147	1.48	700
110	315S	1490	95.8	95.5	0.90	0.87	185	7.2	705.0	2.0	2.2	-	193	180	3.18	940
132	315M	1490	95.5	95.2	0.90	0.89	221	7.0	846.0	2.3	2.5	-	227	210	3.65	1100
160	315LA	1485	95.7	95.5	0.92	0.92	261	7.2	1029.0	2.0	2.2	-	276	252	4.25	1180

This data is provided for guidance only, guaranteed only when confirmed by Regal.

*Meets MEPS High Efficiency level as per AS/NZS 1359.5:2004

PERFORMANCE DATA

HGA SERIES, THREE PHASE, 380-415V 50HZ IP55, F CLASS INSULATION, B CLASS TEMPERATURE RISE

kW	Motor frame	Speed [r/min]	400V 50Hz										t _E time \hat{E} [sec]	380V 50Hz	415V 50Hz	Moment of Inertia J=1/4GD ² (kgm ²)	Weight of foot mount motor (kg)
			Efficiency at % full load		Power factor at % full load		Current		Torque			Current		Current			
			100%	75%	100%	75%	Full load I _N [A]	Locked rotor I _L /I _N	Full load T _N [Nm]	Locked rotor T _L /T _N	Break down T _B /T _N	Full load I _N [A]		Full load I _N [A]			
1000 R/MIN = 6 POLES																	
0.75	90S	930	78.0	78.3	0.71	0.62	2.0	4.4	7.7	2.3	2.6	18	2.0	2.0	0.003	24	
1.1	90L	940	81.3	81.0	0.69	0.60	2.8	5.4	11.2	3.0	3.2	40	2.8	2.8	0.004	30.5	
1.5*	100L	960	84.2	84.4	0.77	0.71	3.4	6.8	15.0	2.2	3.3	23	3.7	3.7	0.008	35	
2.2	112M	960	83.7	83.4	0.72	0.64	5.3	6.0	21.9	2.2	3.6	17	5.6	5.4	0.016	50	
3	132S	960	86.1	86.7	0.76	0.71	6.6	5.9	29.8	1.8	2.2	20	6.8	6.5	0.035	68	
4	132MA	960	87.2	87.4	0.76	0.70	8.8	6.6	39.8	2.0	2.6	18	9.0	8.5	0.041	72	
5.5	132MB	965	87.3	87.9	0.76	0.72	11.9	6.6	54.4	2.0	2.5	13	12.2	11.8	0.051	80	
7.5	160M	970	89.5	89.4	0.79	0.73	15.4	6.4	73.8	2.1	2.8	11	15.6	15.2	0.098	129	
11	160L	975	89.9	89.7	0.78	0.72	22.6	6.9	107.7	2.3	3.1	9	23.0	22.9	0.131	151	
15	180L	980	91.1	91.0	0.81	0.77	29.2	6.1	146.2	1.7	2.4	10	30.8	29.7	0.221	199	
18.5*	200LA	980	92.7	92.4	0.83	0.79	34.7	8.5	180.3	2.2	2.4	12	35.7	34.2	0.345	225	
22	200LB	985	92.5	92.2	0.81	0.76	42.3	8.8	213.3	2.4	3.2	9	43	43	0.37	255	
30	225M	985	92.6	92.5	0.86	0.84	54	6.9	290.9	2.0	2.2	11	57	52	0.66	325	
37	250M	986	93.2	93.0	0.89	0.87	65	8.0	358.4	2.2	2.4	11	67	62	0.84	410	
45	280S	989	93.5	93.1	0.89	0.88	78	7.8	434.5	1.9	2.1	15	83	76	1.41	530	
55	280M	987	94.2	93.7	0.88	0.86	96	9.0	532.2	2.0	2.2	14	99	93	1.68	600	
75	315S	985	94.4	94.1	0.88	0.85	131	7.0	727.2	2.0	2.2	-	137	126	4.111	990	
90	315M	990	95.0	94.7	0.88	0.86	155	7.1	868.2	2.0	2.2	-	164	151	4.81	1080	
110	315LA	991	95.4	95.0	0.88	0.86	189	7.0	1060.0	1.8	2.0	-	198	184	5.45	1150	
132	315LB	993	95.6	95.2	0.87	0.85	229	7.8	1269.5	2.1	2.3	-	238	222	6.15	1320	
750 R/MIN = 8 POLES																	
0.75*	100LA	710	78.3	77.8	0.65	0.58	2.1	4.6	10.1	2.2	2.8	23	2.1	2.1	0.011	36	
1.1	100LB	705	77.6	77.5	0.69	0.63	3.0	4.4	14.9	2.2	2.7	26	3.0	3.0	0.013	38	
1.5	112M	700	79.1	78.8	0.64	0.56	4.3	5.0	20.5	2.9	3.2	33	4.3	4.3	0.026	47	
2.2*	132S	715	85.1	85.1	0.73	0.65	5.1	5.6	29.4	2.2	2.9	20	5.2	5.1	0.035	66	
3*	132M	715	85.1	85.6	0.73	0.66	7.0	5.8	40.1	2.7	3.1	15	7.1	6.9	0.045	82	
4*	160MA	725	88.3	88.2	0.70	0.65	9.3	6.1	52.7	2.2	2.4	14	9.5	9.1	0.078	118	
5.5*	160MB	730	89.4	89.3	0.72	0.65	12.4	6.5	72.0	2.1	2.7	10	12.6	12.4	0.095	129	
7.5	160L	720	87.5	88.1	0.75	0.69	16.4	6.3	99.5	2.5	2.9	9	16.8	16.2	0.135	149	
11	180L	730	88.7	88.9	0.73	0.66	24.6	5.7	143.9	2.1	2.4	10	24.8	24.5	0.229	168	
15	200L	735	90.8	90.8	0.73	0.66	32.4	6.6	194.9	2.2	2.4	10	33.0	32.5	0.341	255	
18.5	225S	735	91.4	91.6	0.76	0.72	38.5	5.6	240.4	1.8	2.0	16	40.5	37.0	0.495	271	
22*	225M	730	92.0	92.4	0.79	0.76	44.0	5.2	287.8	1.8	2.0	14	46	42.5	0.551	290	
30	250M	735	92.1	91.6	0.81	0.76	59	6.9	389.8	2.0	2.2	16	60	58	0.84	428	
37	280S	735	93.0	92.7	0.79	0.75	73	6.8	480.7	2.0	2.2	15	74	69	1.41	520	
45	280M	741	93.5	93.3	0.81	0.78	86	6.7	580.0	2.0	2.2	15	87	84	1.67	633	
55	315S	742	93.7	93.1	0.84	0.81	101	7.1	707.9	1.8	2.0	-	108	98	4.81	1000	
75	315M	742	94.7	94.3	0.82	0.78	139	7.3	965.3	1.9	2.1	-	144	136	5.65	1100	
90	315LA	742	94.8	94.4	0.79	0.76	173	6.3	1158.4	1.8	2.0	-	176	168	6.45	1160	
110	315LB	740	95.3	95.0	0.81	0.78	205	6.5	1419.6	1.8	2.0	-	215	203	7.35	1280	

This data is provided for guidance only, guaranteed only when confirmed by Regal.

*Meets MEPS High Efficiency level as per AS/NZS 1359.5:2004

DIMENSIONAL DRAWINGS

FOOT MOUNT B3 (IM1001)

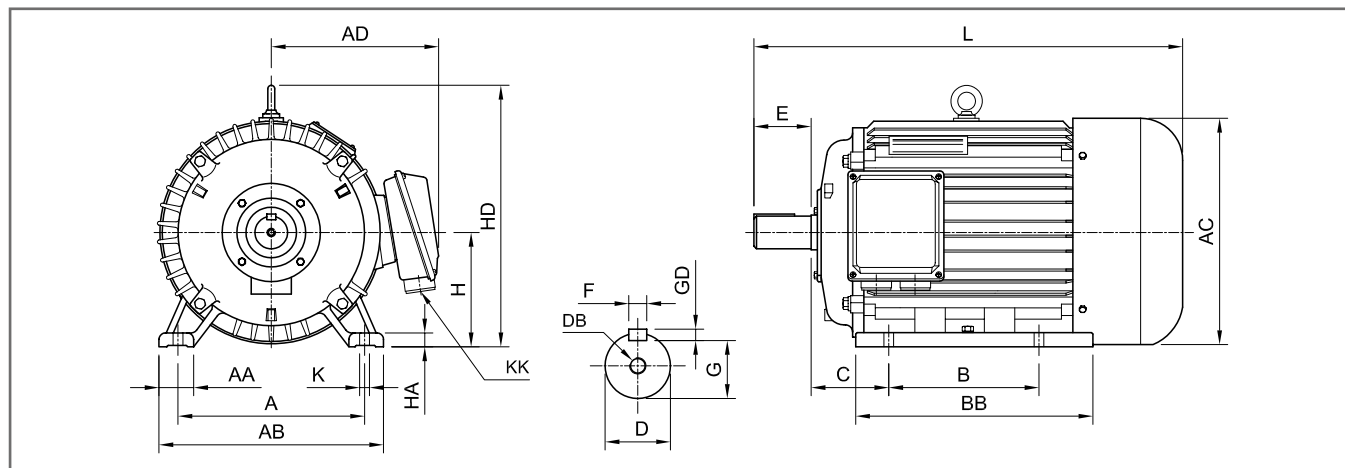

FOOT MOUNT B3 (IM1001)

Motor frame	Mounting Dimensions (mm)																			
	A	AA	AB	AC	AD	B	BB	C	D	DB	E	F	GD	G	H	HA	HD	K	KK ²⁾	L
80 -19	125	35	160	172	165	100	150	50	19	M6	40	6	6	15.5	80	10	170	10	M20	310
80 -19	125	35	160	172	165	100	150	50	19	M6	40	6	6	15.5	80	10	170	10	M20	310
90S -24	140	36	176	185	170	100	160	56	24	M8	50	8	7	20	90	12	195	10	M20	340
90L -24	140	36	176	185	170	125	185	56	24	M8	50	8	7	20	90	12	195	10	M20	365
100L -28	160	40	200	205	185	140	215	63	28	M10	60	8	7	24	100	14	245	12	M20	410
112M -28	190	50	240	225	190	140	225	70	28	M10	60	8	7	24	112	15	265	12	M25	460
132S -38	216	60	275	265	210	140	200	89	38	M12	80	10	8	33	132	18	315	12	M25	480
132M -38	216	60	275	265	210	178	238	89	38	M12	80	10	8	33	132	18	315	12	M25	520
160M -42	254	70	325	320	265	210	270	108	42	M16	110	12	8	37	160	20	385	15	M32	620
160L -42	254	70	325	320	265	254	314	108	42	M16	110	12	8	37	160	20	385	15	M32	660
180M -48	279	70	350	355	285	241	311	121	48	M16	110	14	9	42.5	180	22	455	15	M40	685
180L -48	279	70	350	355	285	279	349	121	48	M16	110	14	9	42.5	180	22	455	15	M40	720
200L -55	318	70	390	395	315	305	380	133	55	M20	110	16	10	49	200	25	475	19	M50	785
225S -60	356	75	435	445	350	286	368	149	60	M20	140	18	11	53	225	28	530	19	M50	840
225M -60	356	75	435	445	350	311	393	149	60*	M20	140*	18*	11*	53*	225	28	530	19	M50	870*
250M -65	406	80	485	485	370	349	455	168	65*	M20	140*	18*	11*	58*	250	30	570	24	M50	945*
280S -75	457	85	545	545	410	368	530	190	75*	M20	140*	20*	12*	67.5*	280	35	640	24	M50	1025*
280M -75	457	85	545	545	410	419	581	190	75*	M20	140*	20*	12*	67.5*	280	35	640	24	M50	1075*
315S -80	508	120	630	630	535	406	605	216	80*	M20	170*	22*	14*	71*	315	45	750	28	-	1235*
315M -80	508	120	630	630	535	457	660	216	80*	M20	170*	22*	14*	71*	315	45	750	28	-	1285*
315L -80	508	120	630	630	535	508	720	216	80*	M20	170*	22*	14*	71*	315	45	750	28	-	1340*

¹⁾ No eye bolt frame 80.

²⁾ Two conduit entries provided (315 frame has 10mm gland plate).

*2 pole variances

Motor frame	Mounting Dimensions (mm)					
	D	E	F	G	M	N
225M -55	55	110	16	10	49	840
250M -60	60	140	18	11	53	945
280S -65	65	140	18	11	58	1025
280M -65	65	140	18	11	58	1075
315S -65	65	140	18	11	58	1170
315M -65	65	140	18	11	58	1220
315L -65	65	140	18	11	58	1270

OPTIONAL HGAT SERIES

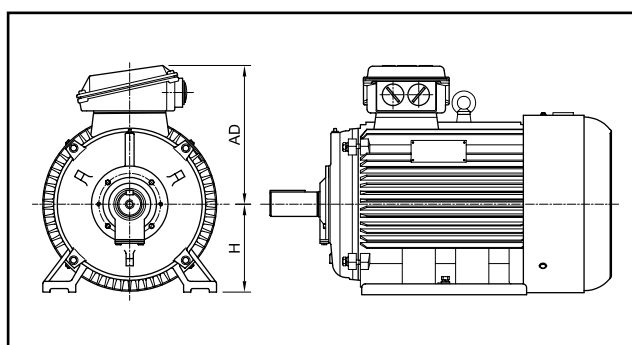

DIMENSIONAL DRAWINGS

LARGE FLANGE MOUNT B5 (IM3001)

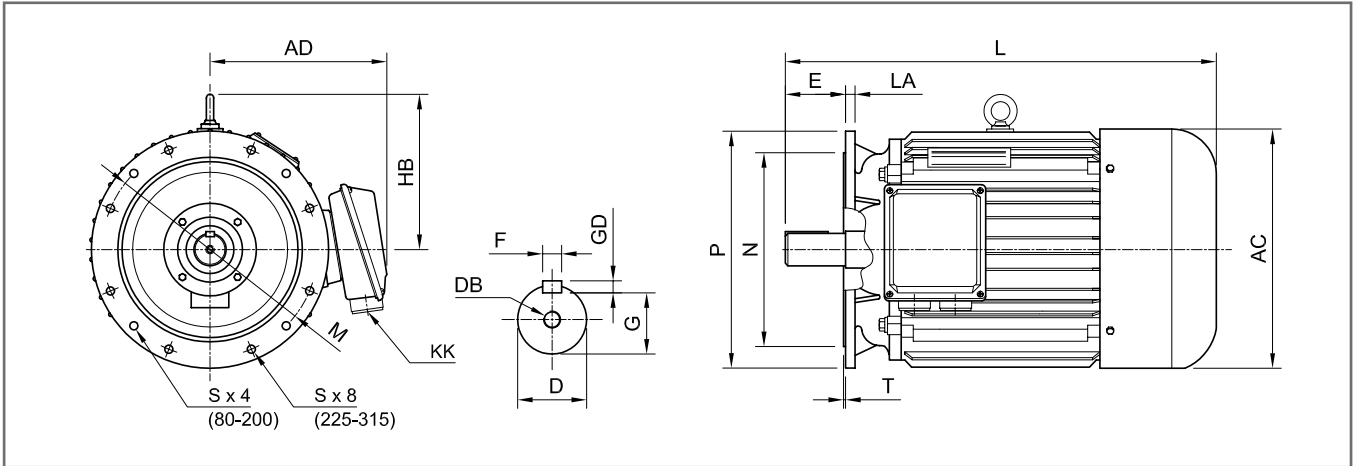

LARGE FLANGE MOUNT B5 (IM3001)

Motor frame	Mounting Dimensions (mm)																	
	AC	AD	D	DB	E	F	GD	G	HB	KK ²⁾	L	LA	M	N	P	S	T	
80	-19	172	165	19	M6	40	6	6	15.5	90	M20	310	12	165	130	200	12	3.5
90S	-24	185	170	24	M8	50	8	7	20	105	M20	340	12	165	130	200	12	3.5
90L	-24	185	170	24	M8	50	8	7	20	105	M20	365	12	165	130	200	12	3.5
100L	-28	205	185	28	M10	60	8	7	24	145	M20	410	12	215	180	250	15	4.0
112M	-28	225	190	28	M10	60	8	7	24	153	M25	460	12	215	180	250	15	4.0
132S	-38	265	210	38	M12	80	10	8	33	183	M25	480	12	265	230	300	15	4.0
132M	-38	265	210	38	M12	80	10	8	33	183	M25	520	12	265	230	300	15	4.0
160M	-42	320	265	42	M16	110	12	8	37	225	M32	620	16	300	250	350	19	5.0
160L	-42	320	265	42	M16	110	12	8	37	225	M32	660	16	300	250	350	19	5.0
180M	-48	355	285	48	M16	110	14	9	42.5	275	M40	685	18	300	250	350	19	5.0
180L	-48	355	285	48	M16	110	14	9	42.5	275	M40	720	18	300	250	350	19	5.0
200L	-55	395	315	55	M20	110	16	10	49	275	M50	785	18	350	300	400	19	5.0
225S	-60	445	350	60	M20	140	18	11	53	305	M50	840	20	400	350	450	19	5.0
225M	-60	445	350	60*	M20	140*	18*	11*	53*	305	M50	870*	20	400	350	450	19	5.0
250M	-65	485	370	65*	M20	140*	18*	11*	58*	320	M50	945*	22	500	450	550	19	5.0
280S	-75	545	410	75*	M20	140*	20*	12*	67.5*	360	M50	1025*	22	500	450	550	19	5.0
280M	-75	545	410	75*	M20	140*	20*	12*	67.5*	360	M50	1075*	22	500	450	550	19	5.0
315S	-80	630	535	80*	M20	170*	22*	14*	71*	435	-	1235*	25	600	550	660	24	6.0
315M	-80	630	535	80*	M20	170*	22*	14*	71*	435	-	1285*	25	600	550	660	24	6.0
315L	-80	630	535	80*	M20	170*	22*	14*	71*	435	-	1340*	25	600	550	660	24	6.0

¹⁾ No eye bolt frame 80.

²⁾ Two conduit entries provided (315 frame has 10mm gland plate).

*2 pole variances

Motor frame	Mounting Dimensions (mm)					
	D	E	F	GD	G	L
225M	-55	55	110	16	10	840
250M	-60	60	140	18	11	945
280S	-65	65	140	18	11	1025
280M	-65	65	140	18	11	1075
315S	-65	65	140	18	11	1170
315M	-65	65	140	18	11	1220
315L	-65	65	140	18	11	1270

DIMENSIONAL DRAWINGS

SMALL FLANGE (FACE) MOUNT B14 (IM3601)

B14A

Motor frame		Mounting Dimensions (mm)				
		M	N	P	S	T
80	- 19	100	80	120	M6	3.0
90	- 24	115	95	140	M8	3.0
100	- 28	130	110	160	M8	3.5
112	- 28	130	110	160	M8	3.5
132	- 38	165	130	200	M10	3.5
160	- 42	215	180	250	M12	4.0

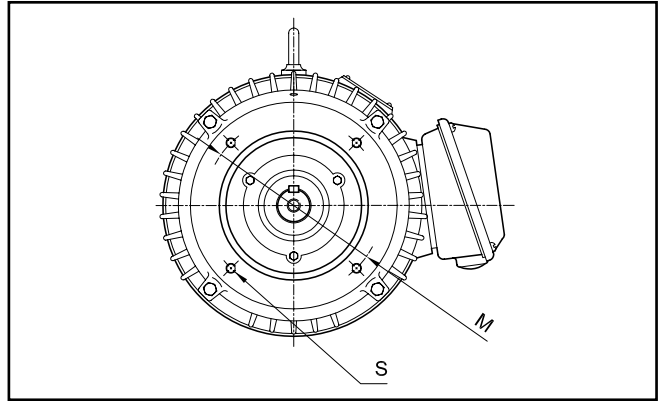

No eye bolt frame 80.

For motor frame and shaft dimensions please refer to large flange mount B5 dimensional drawings (previous page).

B14B

Motor frame		Mounting Dimensions (mm)				
		M	N	P	S	T
80	- 19	130	110	160	M8	3.5
90	- 24	130	110	160	M8	3.5
100	- 28	165	130	200	M10	3.5
112	- 28	165	130	200	M10	3.5
132	- 38	215	180	250	M12	4.0

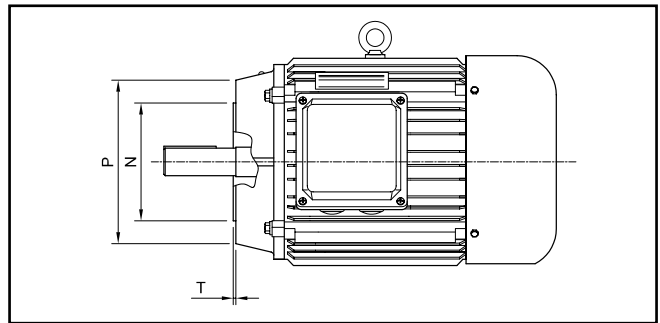

SLIDE RAILS

Slide rails are designed for motor position adjustment when belt drives are used. Applications include tension adjustment for belt driven equipment.

Regal stock slide rails to suit frame sizes 80 to 315. Rail sets are manufactured from cast iron and provided with mounting bolts and nuts between motor and rail.

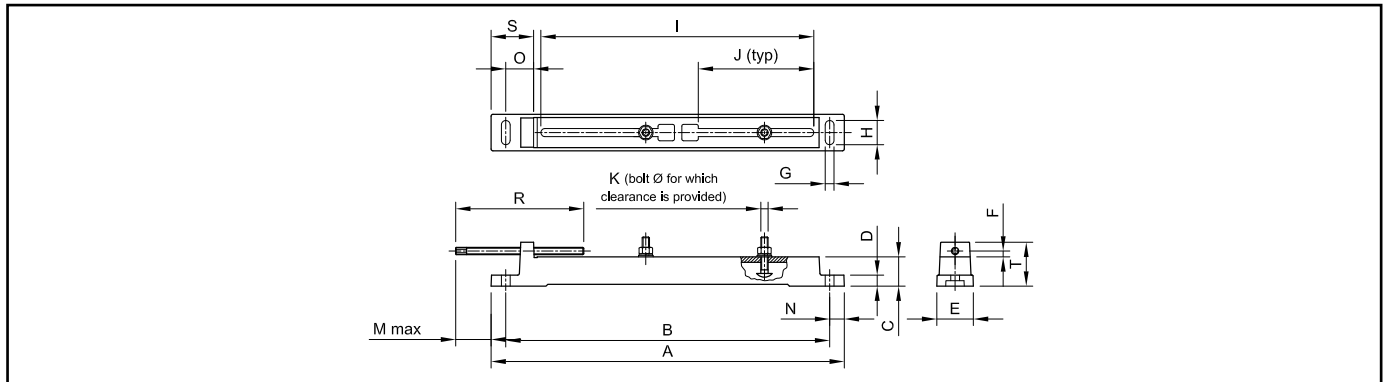

SLIDE RAIL DIMENSIONS

Slide rail product code	To suit motor frame	Mounting Dimensions (mm)																	Weight per set (kg)
		A	B	C	D	E	F	G	H	I	J	K	M	N	O	R	S	T	
MR080090	80 & 90	380	328	30	15	48	10	15	25	245	95	8	75	25	40	145	65	50	3
MR100132	100, 112 & 132	475	425	37	19	70	10	14	35	340	150	10	135	26	42	200	68	62	6.5
MR160180	160 & 180	567	515	48	19	72	11	18	35	390	162	12	115	28	57	200	85	70	10
MR200225	200 & 225	790	730	60	32	92	16	20	20	610	265	16	200	30	60	290	90	92	22
MR250280	250 & 280	945	870	70	38	105	16	21	21	725	305	20	240	35	70	350	105	110	40
MR315355	315 & 355	1220	1115	125	40	122	22	30	30	920	420	24	285	50	105	450	155	170	105

AIRSTREAM RATED MOTORS FOR AXIAL FANS -HGAR

Regal offer a comprehensive range of motors specifically built for use with axial flow fans, where the motor is mounted in the airstream.

Provided the airstream ensures ample cooling, the fan and cowl normally fitted to a standard TEFC motor is redundant. Enclosure rating of the motor is also improved with the use of a solid rear endshield.

Due to the elimination of losses associated with the motor fan these motors have a higher efficiency than standard HGA motors.

STANDARD MOUNT - HGAR (B3, B5, B3/B5)

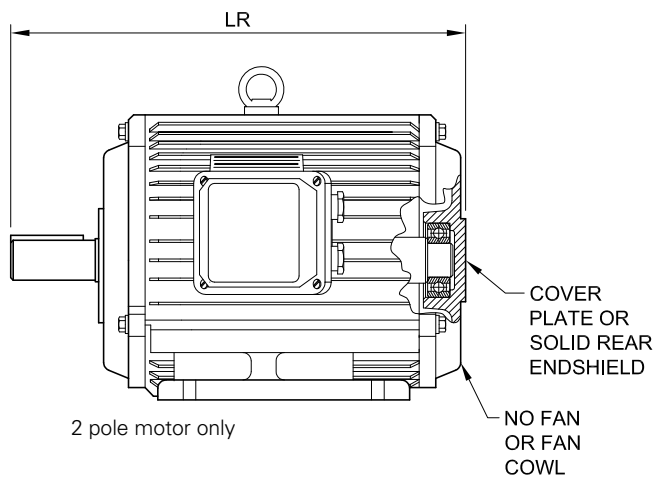

Motor frame	Dimension [LR]	Motor frame	Dimension [LR]	Motor frame	Dimension [LR]
80	265	180M	595	315S	1050
90S	300	180L	635	315M*	1070
90L	325	200L	685	315M	1100
100L	360	225S	725	315L*	1120
112M	390	225M	750	315L	1150
132S	400	250M	825		
132M	440	280S	890		
160M	540	280M	940		
160L	585	315S*	1020		

HGARF is a popular alternative to HGAR, with the terminal box replaced by blanking plate and extended leads (see page 29 for details on blanking plates and extended leads). In this case, terminal box and block are supplied loose with motor for convenience of remote leads termination. These motors are also available in H class insulation (HGARHF).

COOLING TOWER - HGAC

HGAC (formerly HGACT) cooling tower motors are specially developed for operation in air stream rated cooling towers. HGAC motors are available in frame sizes 80 to 315, and rated power outputs of 0.75 to 160kW.

APPLICATIONS

HGAC motors are ideally suited to the cooling tower application, in industries such as food and beverage, airconditioning, chemical processing, and petrochemical.

PROTECTION

Regal HGAC motors have a protection rating of IP66 for maximum protection against water and dust.

ADDITIONAL ENHANCEMENTS

- 2 part epoxy coated for excellent protection against corrosive solids and liquids
- Stainless steel name plate
- Corrosion protection on threads
- Extra insulation coating (Red Isonel 300)
- Shaft seal fitted
- Silastic sealed
- Non-drive end shaft extension cut and blanking plate fitted. Alternatively, HGAR used as base motor.

PAINT

Standard paint finish for HGAC motors is a 2 part epoxy RAL 9005 Jet Black paint. Regal Australia's HGAC range of cooling tower motors combine the HGA's standard high strength and high efficiency with significant enhancements to give the perfect motor for cooling tower applications.

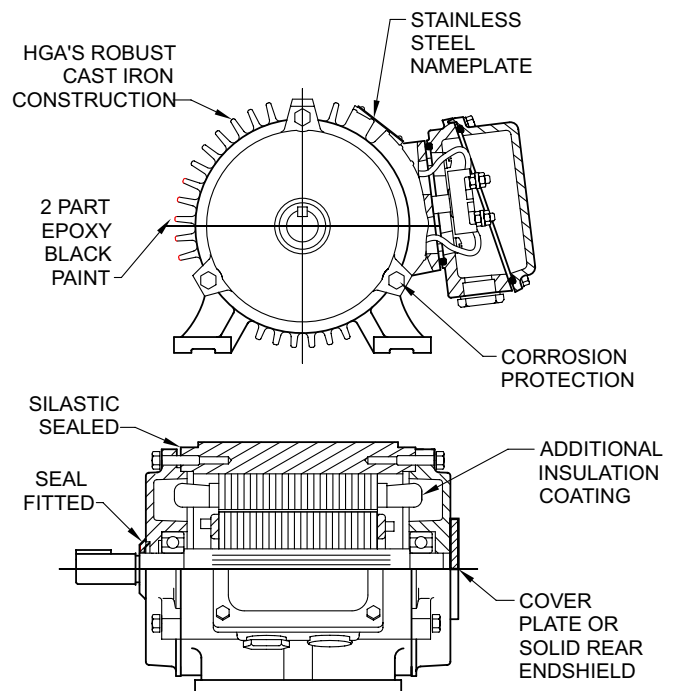

SMOKESPILL - HGAS/HGAHS

Smokespill application motors are designed to withstand the extreme environmental conditions associated with a building fire. Ventilation systems within public buildings are required to continue providing smoke extraction for 2 hours at smokespill air temperature of 200°C or for 30 minutes at 300°C, designated respectively as rating-1 or rating-2 in accordance with AS/NZS1668.1.

The standard HGAS range, wound with F class insulation in frame sizes 80A to 180L, meet the rating-1 requirements. HGAHS range, wound with H class insulation in frame sizes 80A to 315L, meet either rating-1 or rating-2 requirements. HGAHS range is also suitable for applications at 300°C for 2 hours.

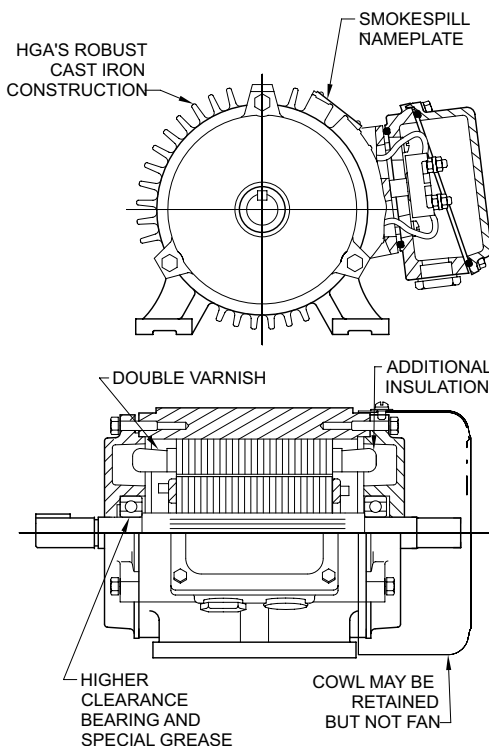

SMOKESPILL FEATURES

The standard HGA motor is inherently suitable for upgrading to the smokespill application due to its low temperature rise. When HGAS motors are ordered F class motors are modified and when HGAHS motors are ordered H class motors are modified in accordance with our standard operating procedures which include the following:

- C3 internal clearance bearings lubricated with extra high temperature specification grease
- Special name plate specifying smokespill suitability
- Double insulated terminal leads
- Double varnish system for winding crown
- Fan and cowl removed if present on the original motor; cowl may sometimes remain to protect from bare shaft
- Motors tested prior to despatch
- Extra High Temperature Grease (Magnalube G)

CERTIFICATION AND TESTING

Australian standard AS4429 specifies the methods of test and rating requirements for smokespill fans. A range of motors was selected in consultation with a competent authority on this subject. Testing of motors was carried out in a specially designed re-circulating duct system. The test rig and the methods of test were also witness approved by a competent authority. A series of tests were conducted to certify our entire range of HGAS and HGAHS motors.

T.E.A.S.R. (TOTALLY ENCLOSED AIR STREAM RATED - NO FAN OR COWL)

The HGAS range is normally supplied without fan and cowl, relying on the air flow generated by the driven fan to provide the necessary cooling during normal operation thereby ensuring high temperature operation will not cause the plastic fan to melt.

Motors are normally supplied with the non drive end stub shaft exposed, as it is expected to be shrouded by the fan housing and duct work when installed. If this presents a problem in a specific application, either removal of this shaft can be requested, or the standard fan cowl can be fitted, but without the motor fan. Alternatively the HGAR series can be used as the base motor.

TERMINATIONS

HGAS motors can be supplied either with terminal boxes or with extended leads through a gland plate (see page 29 for details). In either case, it is the installers responsibility to ensure that suitable high temperature leads, conduit and fittings are installed to take the motor leads outside the fan case. Regal Australia can supply terminal boxes and terminal blocks for installation outside the fan drum if required.

PAINT

Standard color finish for the HGAS range is RAL 7012 Basalt Grey, and RAL 3000 Flame Red for the HGAHS range. Other colors are available on request.

NAMEPLATES

Regal Australia Smokespill motors are marked with special nameplates labelling its suitability for smokespill duty and stating specific temperature condition ratings and lubrication details. Additional plates for external mounting to fan assemblies are available on request.

MAINTENANCE

Because of the safety related nature of smokespill motors proper maintenance schedules are imperative, especially where the motor is used for dual purposes ie. continuous running for normal ventilation as well as for smokespill application. Serious consideration needs to be given to bearing and insulation deterioration caused by use for extended periods for normal ventilation duty. It is important that the motor remains within its stated rating both on initial commissioning and after any adjustments to the ventilation system.

BRAKE MOTORS - HGAB

Regal offers a wide range of Brake motors, HGAB, from frame size 80 through to 180. 4 pole models are stocked as standard. 2,6 and 8 pole and other non-standard sizes and speeds are available on special order. HGAB brake motors are "fail to safe" design, as the brake will engage when power is interrupted.

Brake motors are designed for use in applications requiring rapid stopping, holding and position control. HGAB motors are available in all mounting arrangements. Brakes are made to the 'Euro' standard mounting dimension, providing interchangeability with other brands. Cast iron brake enclosures for hazardous locations are also available.

DIMENSIONS

The only dimensional variations of HGAB from HGA is the overall motor length, due to the extended length of the cowl. These dimensional variations are listed in the accompanying table. Overall length L is replaced by LB.

CONNECTION

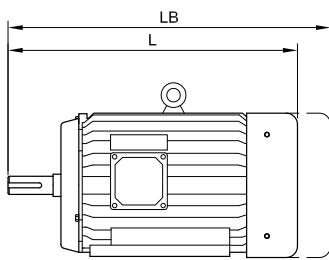

Motor frame	Brake motor overall length (LB)
80	360
90S	395
90L	420
100L	480
112M	525
132S	570
132M	615
160M	700
160L	745
180M	790
180L	830

BRAKE DETAILS

Output kW	Motor frame	Brake model	Brake weight [kg]	Motor full load torque T_N [Nm]
0.75	80B-4	M8	1.8	5.0
1.1	90S-4	M16	3.4	7.4
1.5	90L-4	M16	3.4	10.0
2.2	100LA-4	M32	4.5	14.4
3	100LB-4	M32	4.5	19.6
4	112M-4	M60	7.4	26.3
5.5	132S-4	M60	7.4	36.0
7.5	132M-4	M100	13.6	49.2
11	160M-4	M150	19.0	71.5
15	160L-4	M150	19.0	97.4
18.5	180M-4	M250	33.0	120.2
22	180L-4	M250	33.0	142.9

Brake torque [Nm]		
Nominal	Min	Max
8	2.8	10
16	5.5	20
16	5.5	20
32	11	40
32	11	40
60	20	75
60	20	75
100	35	125
150	50	185
150	50	185
250	90	310
250	90	310

Brake torque [% of full load]		
Nominal	Min	Max
160%	50%	200%
220%	70%	270%
160%	50%	190%
220%	80%	270%
160%	60%	200%
220%	70%	280%
160%	50%	200%
200%	70%	250%
210%	70%	260%
150%	50%	190%
210%	80%	260%
180%	60%	220%

For further technical details regarding the brake, please contact your nearest Regal Australia office.

HGAB motors 3kW and below are connected in 415V star connection with brake connected as shown below left. HGAB motors 4kW and above are connected in 415 volt delta connection with brake connected as shown below right.

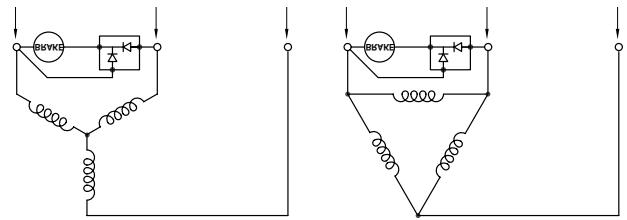

The HGAB 3 phase motor is fitted with a CE certified DC brake and half wave rectifier mounted in the terminal box enabling direct connection of the brake to the AC supply.

Where response time is important, this time can be improved by switching the brake on the DC current side of the rectifier. These additional terminals are standard on the rectifier fitted to the 160 to 180 frame motors as shown below.

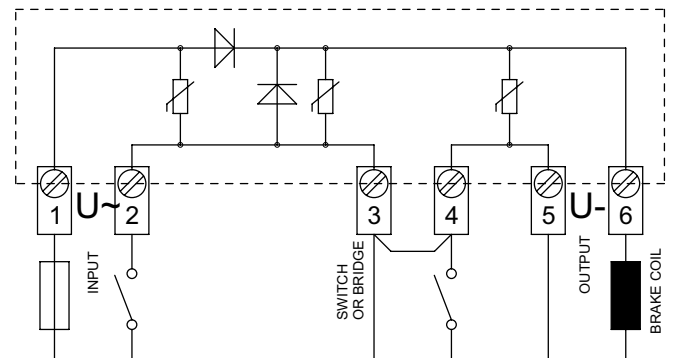

MOTORS FOR HAZARDOUS AREAS

HGAE/HGAN/HGAD

Motors used within a hazardous location require a higher level of protection against the risk of harmful occurrences. Regal Australia HGA motors are available in the three most common high protection configurations, Ex e, Ex nA and Ex tD, supplied with protection ratings IP55, IP65 or IP66. HGA Hazardous area motors are available in motor frame sizes 80 to 315, with 315 frame available Ex nA and Ex tD only. Combinations of protection such as Ex e and Ex tD or Ex nA and Ex tD are also available.

INTERNATIONAL AND AUSTRALIAN STANDARDS

IEC or AS/NZS 61241.1 specify general requirements for the selection of electrical equipment, and its installation and maintenance to ensure safe use in areas where flammable materials are generated, prepared, processed, handled, stored or otherwise used, and which are therefore potentially hazardous.

The term 'flammable material' includes gases, vapors, liquids, mists, solids and dusts, but does not include those materials which are specifically manufactured as explosives or materials which are inherently explosive. The requirements of the listed standards apply only to the use of electrical equipment under normal or near normal atmospheric conditions.

The requirements specified for hazardous location electrical equipment are supplementary to and not alternative to any requirements which would apply to equipment and installations in non-hazardous areas (see AS/NZS3000).

PAINT

Standard color finish for the hazardous area range is RAL 7030 Stone Grey, with primary option of RAL 1004 Golden Yellow for HGAE. Other colors are available on request.

MOTOR PROTECTION TYPES

HGAE - Ex e

Ex e motor protection designates Increased safety as outlined in IEC, EN or AS/NZS 60079-7.

The increased safety (Ex e) type of protection describes electrical equipment that does not produce arcs or sparks in normal service in which additional measures are applied so as to give increased security against the possibility of excessive temperatures and of the occurrence of arcs and sparks.

Increased safety (Ex e) motors are suitable for Class I, Zone 1, Group II (A,B&C) hazardous areas, and Regal Australia provides for a temperature class of T3 (200°C) in a 40°C ambient (see next page for explanations of classes, zones and groups).

Ex e Protection - t_E time

t_E time is the time it takes for the stator winding or rotor cage to heat up from normal operating temperature, at the highest permitted ambient temperature, to the highest permitted limit temperature (temperature class), with the rotor locked and the stator winding loaded with the starting current.

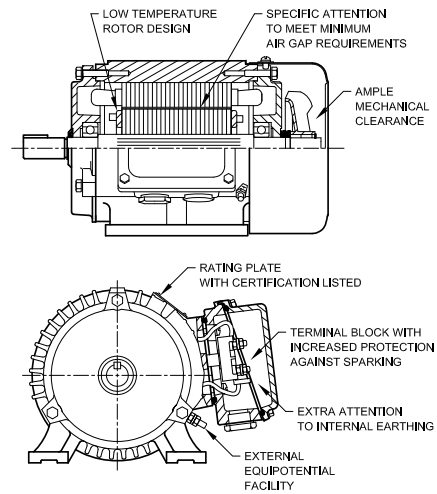

For selection and setting of suitable current dependent protection the t_E time and the ratio of locked rotor current to nominal current are used. In the case of a rotor locking, this device must cut off the supply within the specified t_E time, which is listed in the performance data.

HGAN - Ex nA

Ex nA motor protection designates Non-sparking as outlined in IEC, EN or AS/NZS 60079-15. Non-sparking (Ex nA) type of protection describes electrical equipment that, in normal operation, is not capable of igniting a surrounding explosive atmosphere, and a fault capable of causing ignition is not likely to occur.

Non-sparking (Ex nA) motors are suitable for Class I, Zone 2, Group II (A,B&C) hazardous areas, and Regal Australia provides for a temperature class of T3 (200°C) in a 50°C ambient.

HGAD - Ex tD

Ex tD motor protection designates dust-excluding ignition proofing as outlined in IEC or AS/NZS61241 series of standards.

Dust-excluding ignition proofing (Ex tD) type of protection describes electrical equipment which is enclosed so that it excludes dust, and which will not permit arcs, sparks or heat otherwise generated or liberated inside the enclosure to cause ignition of exterior accumulations or atmospheric suspensions of a specific dust on or in the vicinity of the enclosure. Dust-excluding ignition proofed (Ex tD) motors are suitable for Zone 21 and 22 dust laden hazardous areas, and Regal Australia provides for a temperature class of T4 (135°C) in a 50°C ambient.

HAZARDOUS AREA CLASSIFICATIONS

Hazardous areas fall into two categories; hazards due to flammable gases (vapors or mists), and hazards due to combustible dusts (fibres or particles).

Gaseous hazards

Explosive gas atmospheres are classified into zones based on the frequency and duration of their occurrence as below:

Zone 0: an area in which an explosive gas atmosphere is present continuously, for long periods, or is present frequently.

Zone 1: an area in which an explosive gas atmosphere is likely to occur in normal operation occasionally.

Zone 2: an area in which an explosive gas atmosphere is not likely to occur in normal operation, and if it does occur it will exist for a short period only.

Electrical apparatus for potentially explosive atmospheres is divided into the following groups:

Group I: mines susceptible to fire damp (methane).

Group II: other industries.

High surface temperatures can cause ignition of flammable gases or vapors therefore the surface temperature of equipment in hazardous areas must not exceed the ignition temperature of these gases or vapors.

Group I electrical equipment may not have a surface temperature that exceeds 150°C where coal dust can form a layer, and 450°C for internal surfaces where the above risk is avoided by sealing against ingress or dust.

Group II electrical equipment may not have a surface temperature that exceeds its specified temperature class, as listed in the table below:

Temperature class of electrical equipment	Maximum surface temperature of electrical equipment	Ignition temperature of gas or vapor
T1	≤ 450°C	> 450°C
T2	≤ 300°C	> 300°C
T3	≤ 200°C	> 200°C
T4	≤ 135°C	> 135°C
T5	≤ 100°C	> 100°C
T6	≤ 85°C	> 85°C

Electrical apparatus of Group II may be subdivided according to the nature of the potentially explosive atmosphere for which it is intended.

Group specification and characteristics of some common flammable liquids, gases, and vapors are listed in the table below:

Material	Boiling point [°C]	Flash point [°C]	Ignition temp. [°C]	Gas group
Acetone	56	-20	465	IIA
Acetylene	-83	Gas	305	IIC
Ammonia	-33	Gas	651	IIA
Benzene	80	12	498	IIA
Butane	-1	Gas	287	IIA
Carbon monoxide	-192	Gas	609	IIA
Ethane	-89	Gas	472	IIA
Ethyl alcohol	78	55	363	IIA
Ethylene	-104	Gas	450	IIB
Heptane	98	-4	204	IIA
Hydrogen	-252	Gas	500	IIC
Hydrogen cyanide	26	-18	538	IIB
Methane	-162	Gas	537	IIA
Propane	-42	Gas	432	IIA
Toluene	111	4	480	IIA

NOTE: The data given in this table is derived from NFPA 325M. Flashpoint is the lowest temperature at which a material gives off sufficient vapor to form an explosive gas/air mixture in the air immediately above the surface.

Equipment within a specific group may only be used within a location with an equal or less level of hazard. Allowable groups are summarized in the table below:

Gas group	Allowable equipment group
IIA	IIA, IIB, IIC
IIB	IIB, IIC
IIC	IIC

Combustible dust hazards

Many dusts which are generated, processed, handled and stored, are combustible. When ignited, they can burn rapidly and with considerable explosive force if mixed with air in the appropriate proportions. Electrical apparatus used in locations where this hazard is present, requires adequate protection so as to reduce the likelihood of ignition of the external explosive atmosphere.

Areas where dusts, flyings and fibres in air occur in dangerous quantities are classified as hazardous and are divided into three zones according to the level of risk.

Zone 20: An area in which combustible dust, as a cloud, is present continuously or frequently during normal operation, in sufficient quantity to be capable of producing an explosive dust/air mixture, and/or where layers of dust of uncontrollable and excessive thickness can be formed.

Zone 21: An area not classified as Zone 20 in which combustible dust, as a cloud, is likely to occur during normal operation, in sufficient quantities to be capable of producing an explosive dust/air mixture.

Zone 22: An area not classified as Zone 21 in which combustible dust clouds may occur infrequently, and persist for only a short period, or in which accumulations or layers of combustible dust may be present under abnormal conditions and give rise to combustible dust/air mixtures. Where, following an abnormal condition, the removal of dust accumulations or layers cannot be assured then the area is to be classified.

Ignition protection is based on the limitation of the maximum surface temperature of the enclosure and on other surfaces which could be in contact with dust and on the restriction of dust ingress into the enclosure by the use of dust tight or dust protected enclosures.

The following table summarizes the relationship between temperature class, surface temperature and cloud or layer ignition temperature (whichever is the lower).

Temperature class of electrical equipment	Maximum surface temperature of electrical equipment	Cloud or layer ignition temperature of dust
T1	≤ 450°C	≥ 500°C
T2	≤ 300°C	≥ 350°C
T3	≤ 200°C	≥ 250°C
T4	≤ 135°C	≥ 185°C
T5	≤ 100°C	≥ 150°C
T6	≤ 85°C	≥ 135°C

Specifications and characteristics of some common combustible dusts are listed in the table below:

Material	Minimum ignition energy [mJ]	Ignition temperature	
		Cloud [°C]	Layer [°C]
Aluminium	15	550	740
Cellulose	80	480	270
Corn	40	400	250
Flax	80	230	430
Polypropylene	30	420	-
Rayon	2400	520	250
Rice	50	440	220
Rubber (synthetic)	30	320	-
Sugar	30	370	400
Wheat flour	50	380	360

MODIFICATIONS, VARIATIONS AND OPTIONAL EXTRAS

Regal offers an extensive range of variations to the HGA motor series. Other HGA ranges outlined in other sections include:

Brake motors	- HGAB
Smokespill applications	- HGAS and HGAHS
Airstream motors for axial fans	- HGAR, HGARF and HGARHF
Cooling tower motors	- HGAC
Hazardous area motors	- HGAE, HGAN and HGAD

Additional to these motor ranges Regal Australia offer a large array of modifications available on order. These modifications are outlined below.

TERMINAL BOX

HGA motors come standard with a terminal box on the right hand side viewed from drive end. The following alternatives are available:

Left hand terminal box	- HGAL
Top mounted terminal box	- HGAT
Removed terminal box (fitted with a blanking plate and threaded conduit entry. Extended leads, including earth connector)	- HGAF

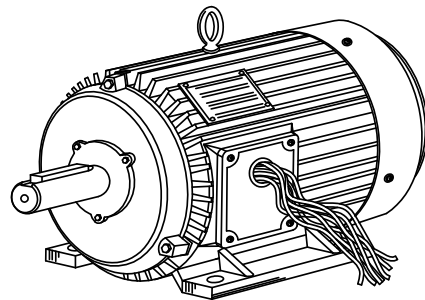

Extended leads: 1.5m
No. of power leads: 3+1 for up to 3kW,
6+1 for 4kW and above

Motor frame	Conduit size
80-132	M25 x 1.5
160-180	M32 x 1.5
200-250	M50 x 1.5
280-315	M63 x 1.5

BEARINGS

Regal can address applications where bearings need special consideration. Attention may need to be given to the following:

- Bearing monitors
- Alternative bearing types
- Low/high temperature bearing grease
- Oil seals
- Non contact labyrinth seals
- Insulated bearings

SHAFTS

HGA motors come standard with a single output shaft to standard dimensions. The following alternatives are available:

- Double shaft extension
- Special shaft extension
- Stainless steel shaft material type
- Reduced shafts for geared motors

ENVIRONMENTAL CONSIDERATIONS

Where environmental factors need special consideration Regal can provide the following modifications:

- Winding temperature monitors and thermistors
- Anti-condensation heaters
- Separately powered cooling fans
- Tropic proofing
- Special paint finish
- Higher International Protection ratings, IP56, IP65 and IP66
- High ambient temperature motors – HGAH with H class insulation

SPECIAL PERFORMANCE

Regal has the ability to provide HGA motors with special windings. These may include:

- Windings for alternative operating voltages and frequencies.
- Windings designed for increased outputs and short time ratings.
- For higher polarities and multispeed, refer to SGA catalogue

VVVF DRIVES

Two types of VVVF drives kit are available for the HGA range to assist in maintaining satisfactory operation.

VVVF DRIVE KIT A - SEPARATELY DRIVEN COOLING FAN (230 & 400V)

This fan should be used when the motor speed is required to be reduced below 25Hz in constant torque mode. For centrifugal fan or pump, no separate cooling fan is required. For all other loads refer to the loadability curve in the section on VVVF Drives, refer page 14.

VVVF DRIVE KIT B - STANDARD MOTOR (EDM)

This kit incorporates a single insulated bearing, normally at the non-drive end, designed to remove the effect of electrical discharge through the bearings.

TESTING SERVICES

Regal can provide both type test certificates and individual motor test reports on any HGA motor.

Type test reports and outline drawings of standard motors are available at www.regalaustralia.com

MARINE APPROVAL

LLOYD'S REGISTER TYPE APPROVAL



Register Type Approval is an independent certification service, which is available for a wide range of products used in marine and offshore applications, industrial plants and processes, and the IT sector.

Type Approval raises awareness of key issues and best-practice benchmarks in emerging manufacturing countries and helps to improve product quality.

Purchasers of products need to be confident that the suppliers they select are capable of providing the required standard of components. Regal has always prided itself on a commitment to delivering not only the most suitable product, but the highest standard of product, available for the specific job.

For those Regal products used in marine and offshore applications, a Lloyd's Register Type Approval mark has been awarded. This approval mark encompasses the Regal Australia HGA, HLA, PPA/PPC, SGA and SLA range of motors.

An advertisement for CMG motors. At the top, there is a photograph of a large ship at sea. Below the ship, several orange CMG motors are arranged in a circular pattern. The text 'TREADING WATER?' is prominently displayed in the center. Below this, there are three columns of small text providing information about the company's commitment to quality and safety in the marine industry.

TREADING WATER?

As a tough economic climate creates storms around all parts of the world, energy efficiency and quality assurance take precedence over more than ever before. Breakdowns, increasing energy consumption and insurance rates are no longer of average concern, but have developed into potential corporate survival crises.

Don't fret. With over 60 years manufacturing experience in the electric motor industry, **CMG won't leave you drowning.**

Our recent Lloyd's Register Type Approval is a testament to the quality of our products and manufacturing processes. CMG's ability to produce world class electric motors made readily available, is an assurance of our commitment to the Shipping Industry.

Need a lifebuoy?

marathon®

Motors

HEAD OFFICE - AUSTRALIA

Regal Beloit Australia Pty Ltd ABN 61 122 303 084
19 Corporate Ave (PO Box 2340)
Rowville VIC 3178, Australia
Customer Service: 1300 888 853
T: +61 3 9237 4040
F: +61 3 9237 4050
salesAUvic@regalbeloit.com
www.regalaustralia.com.au

STATE OFFICES

VICTORIA

19 Corporate Avenue
Rowville VIC 3178
T: 1300 888 853
F: +61 3 9237 4050

NEW SOUTH WALES

8 Bushells Place
Wetherill Park NSW 2164
T: 1300 888 853
F: +61 2 8781 3131

QUEENSLAND

7 Mahogany Court
Willawong QLD 4110
T: 1300 888 853
F: +61 7 3246 3210

PRESENT IN

MACKAY

SOUTH AUSTRALIA

WESTERN AUSTRALIA

T: 1300 888 853

NEW ZEALAND

Regal Beloit New Zealand Limited
18 Jomac Place Avondale
Auckland, New Zealand
T: 0800 676 722
F: +64 9 820 8504

PRESENT IN

CHRISTCHURCH

ROTORUA

T: 0800 676 722

SINGAPORE, MALAYSIA

Regal Beloit Malaysia Sdn. Bhd. (613268-T)
Lot No. 27305, Jalan P/1A,
Kawasan Perindustrian Bangi,
43650 Bandar Baru Bangi, Selangor,
Singapore Malaysia
T: +603 8751 1888
salesSG@regalbeloit.com

THAILAND

FASCO Motors (Thailand) Limited
29/7-8 Bangkruay-Sainoi Road Bangkrang
Muang Nonthaburi District
Nonthaburi 11000, Thailand
T: +66 2447 3300
F: +66 2447 3500

APPLICATION CONSIDERATIONS

The proper selection and application of motors, motor controls and components, including the related area of product safety, is the responsibility of the customer. Operating and performance requirements and potential associated issues will vary appreciably depending upon the use and application of such products and components. The scope of the technical and application information included in this publication is necessarily limited. Unusual operating environments and conditions, lubrication requirements, loading supports, and other factors can materially affect the application and operating results of the products and components and the customer should carefully review its requirements. Any technical advice or review furnished by Regal Beloit Australia Pty Ltd and its affiliates with respect to the use of products and components is given in good faith and without charge, and Regal assumes no obligation or liability for the advice given, or results obtained, all such advice and review being given and accepted at customer's risk.

For a copy of our Standard Terms and Conditions of Sale, Disclaimers of Warranty and Limitation of Liability, please contact Customer Service at 1300 888 853 or visit www.regalaustralia.com.au. These terms and conditions of sale, disclaimers and limitations of liability apply to any person who may buy, acquire or use a Regal Beloit Australia Pty Ltd product referred to herein, including any person who buys from a licensed distributor of these branded products.

Regal and Marathon are trademarks of Regal Beloit Corporation or one of its affiliated companies.

©2019 Regal Beloit Corporation, All Rights Reserved. MCC19002E • Form# SB0086E

REGAL®